

SATRON VD differential pressure transmitter

BPdV750
November 10, 2004

SATRON VD differential pressure transmitter belongs to V-transmitter family. The series V transmitters have both analog and smart properties. SATRON VD is used for 0-0,1kPa...0-15 MPa ranges. The transmitter communicates in a 2-wire system. In pressure measuring applications SATRON VD transmitters are used for measuring differential pressure and vacuum pressure. SATRON VD transmitter is equipped with an SOS (Silicon On Sapphire) sensing element. The rangeability is 15:1. The transmitter communicates digitally using the HART® protocol.



TECHNICAL SPECIFICATIONS

Measuring range and span

See Selection Chart.

Zero and Span adjustment

Zero elevation: Calibrated span is freely selectable on the specified range depending from the desired option. This can be made by using external control shafts (analog option), keyboard (display option), HART®275 communicator.

Damping

Time constant is continuously adjustable 0,01 to 60 s.

Temperature limits

Sensing element operating:

- 30 to +120 °C

(type VD6 -20 to +120 °C)

Electronics operating: -30 to +80 °C

Shipping and storage: -50 to +80 °C.

Pressure limits

Min. and max. process pressure:

Type	Max. overload pressure, MPa		Pressure class
	CoNi diaphragm	Other diaphragms	
VD2	4	3	PN40
VD3	10	4	PN100
VD4,5	10	6	PN100
VD6	10	10	PN100
VD7	20	20	PN200
*3...5	40	6	PN400
*7	40	40	PN400

* types H and U: See Selection Table.

Transmitter operates within specifications for pressures above 10 mbar abs.

Process chamber volume (cm³)

Type	Volume (cm³)	
	Standard transmitter	With hydraulic seal
VD2	135	-
VD3...7	20	3.30

Process chamber's volumetric displacement

Type	Volumetric displacement (mm³/max. span)	
	Standard transmitter	With hydraulic seal
VD2	800	-
VD3	200	200
VD4	400	400
VD5	470	470
VD6	700	80
VD7	80	80

Output 2-wire (2W), 4-20 mA,

user selectable for linear, square root, inverted signal or the transfer function (16 points) specified by the user

Supply voltage and permissible load

See the load capacity diagram; 4-20 mA output: 12 - 35 VDC.

Humidity limits

0-100 % RH

PERFORMANCE SPECIFICATIONS

Tested in accordance with IEC770: Reference conditions, specified span, no range elevation, horizontal mounting; CoNi diaphragm, silicone oil fill.

Accuracy

±0.2 % of calibrated span (span 1:1-7.5:1 / max.range).

On the measuring ranges 7.5:1-15:1:

$\pm[0.01+0.025 \times (\frac{\text{max. span}}{\text{calibrated span}})]\%$ of calibrated span

(incl. nonlinearity, hysteresis and repeatability)

Long-term stability

±0.25 %/max. span for 12 months

Temperature effect on compensated temperature ranges -20 to 80 °C

Zero and span shift: ±1.0 % of max. span (double for type VD2)

Static pressure effect on Zero of max. span

VD2: ±0.2 % per 4 MPa
VD3...7, PN100: ±0.3 % per 10 MPa;
PN200: ±0.4 % per 20 MPa;
PN400: ±0.6 % per 40 MPa.

Overpressure effect on Zero of max. span

VD2, 3: ±1.0 % per 4 MPa;
VD4...7: PN100/200: ±0.7 % per 10 MPa; PN400: ±2.5 % per 40 MPa.

Mounting position effect

Deviation from horizontal position causes a zero shift that can be calibrated out. (Only horizontal position is recommended for type VD2 transmitters.)

Power supply effect

< ±0.01 % of calibrated span per volt.

EMC-test standards

GENERIC EMISSION STANDARD:

EN 50081 - 2: 1993

Normative reference:

EN 55022:1987/class A

GENERIC IMMUNITY STANDARD:

EN 50082 - 2: 1995

Normative references:

EN 61000-4-2, -4, -5, -8, -11

ENV 50140, ENV 50204, ENV 50141

Insulation test voltage

500 V rms 50 Hz

CONSTRUCTION AND CALIBRATION

Materials

Diaphragms ¹⁾: CoNi alloy, AISI316L or Hast. C276.

Flanges ¹⁾ and vent valves ¹⁾: AISI316 or Hast. C276.

O-ring on sensing element: PTFE.

Other sensing element materials: AISI316, SIS 2343, SIS 2324.

Mounting bolts and nuts for sensor flanges: AISI316 (PN400: m.8.8.Zne)

Fill fluid

Silicone oil (DC200, 10 cSt) or inert oil.

Housing with PLUG connector, H and T

Housing: AISI316

Seals: Viton® and NBR

TEST jacks: MS358Sn/PVDF, protected with silicone rubber shield.

PLUG connector: PA6-GF30 jacket, Silicone rubber seal, AISI316 retaining screw.

Housing with junction box/terminal strip, M and N

Housing: AISI303/316; Seals: Nitrile and Viton®; Nameplates: Polyester

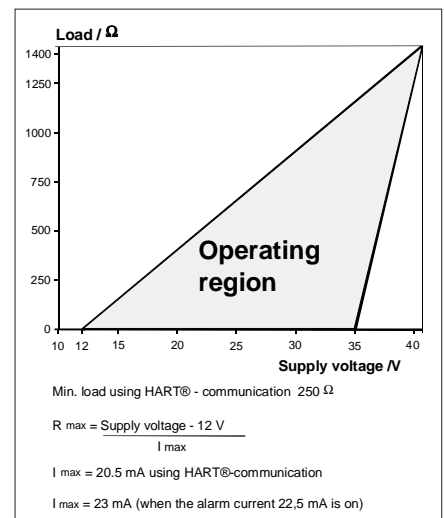

¹⁾ Parts in contact with process medium.

SATRON VD differential pressure transmitter

Connection cable between sensing element and housing

Codes **L** and **K** :

PTFE hose with AISI316 braiding.

Calibration

For customer-specified range with minimum damping. (If range is not specified, transmitter is calibrated for maximum range.)

Enclosure class: IP66.

Electrical connections

Housing with PLUG connector, **H** and **T** :

PLUG connector, connector type DIN 43650 model AF; Pg9 gland for cable; wire gross-section 0.5 to 1.5 mm².

Housing with junction box/terminal strip, **M** and **N** :

Pg13.5, 1/2-NPT inlet; screw terminals for 0.5 to 2.5 mm² wires

Weight (kg)

Type	Housing type		
	H/T	M	N
VD2	8.0	8.6	8.7
VD3...7	5.2	5.8	5.9
VD3...7 (PN400)	6.6	7.2	7.3

Process connections

See Selection Table.

Dimensions (in mm)

M10/deep 18 (PN40 range codes 4..6)

M12/deep 16.5 (PN200 range code 7 / PN400 range codes 4 and 5)

7/16-20 UNF/deep 18 (PN400 for range codes 4 and 5)

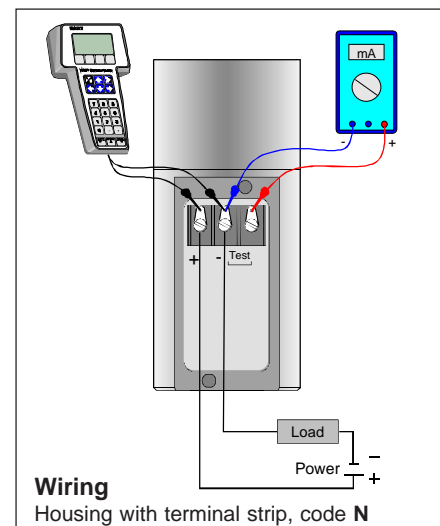
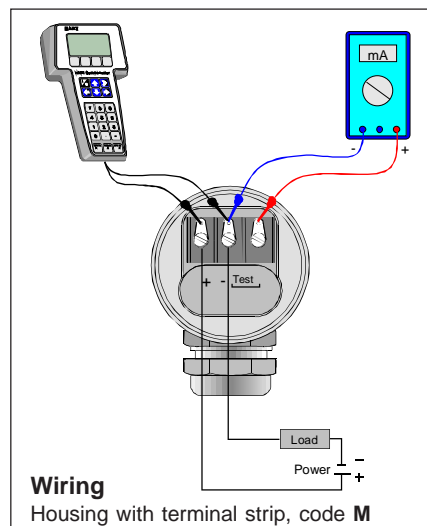
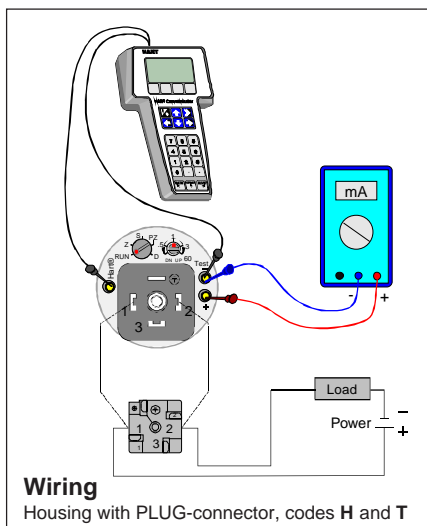
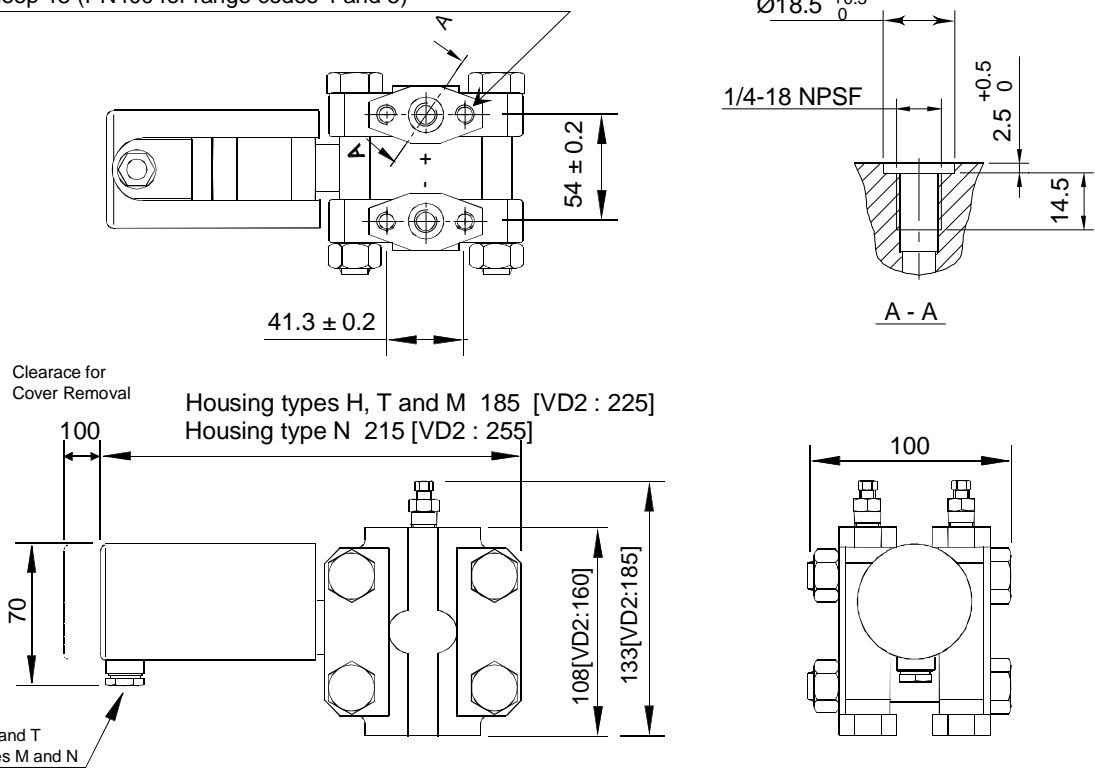

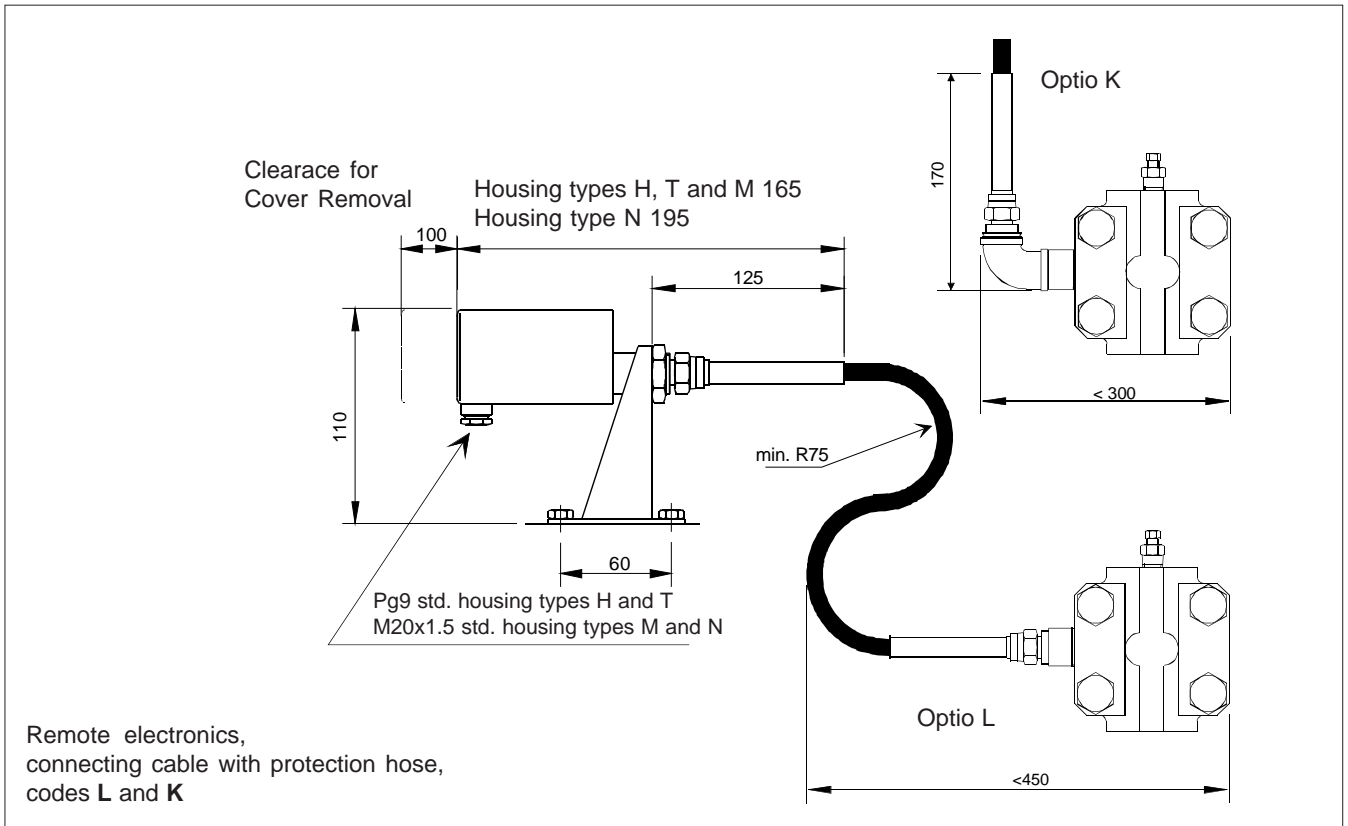

Use of selector switch :

- RUN = working position
- PZ = Process value zero
- D = damping adjustment
- S = Span adjustment
- Z = Zero adjustment
- DN = Down
- UP = Up

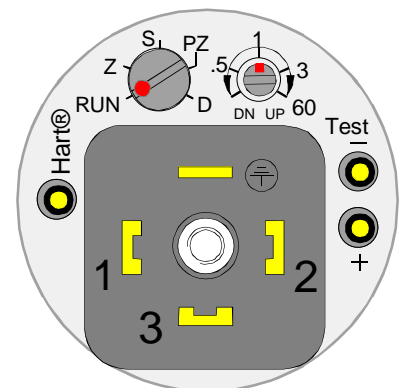

Housing with PLUG-connector, code T

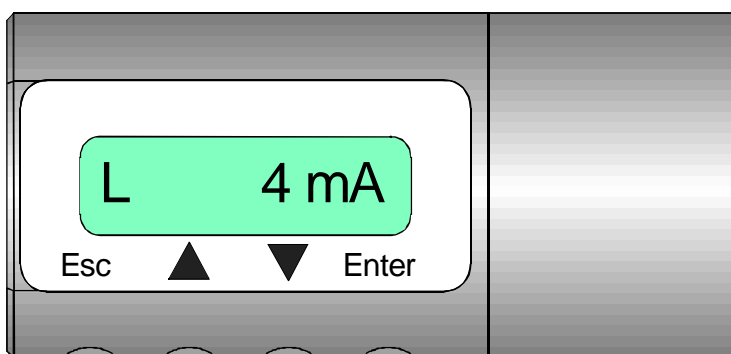

Keyboard :

- Esc = Press **Esc** move back towards the top of the main menu.
- ▲ = Use the **UP** arrow key to move up on the current menu level or to increase the selected parameter value.
- ▼ = Use the **DOWN** arrow key to move down on the current menu level or to decrease the selected parameter value.
- Enter = Press **ENTER** to move to a lower level in a menu or to accept a command or parameter value.

Housing with display, code N

SATRON VD differential pressure transmitter

BPdV750
November 10, 2004

Selection Chart

VD	Differential Pressure Transmitter		
VA	Absolute Pressure Transmitter (ranges 4 to 7, measuring range 0...xx, abs.)		

Adjustability (±)			
	Span, min.	Span, max.	Measuring range
2	0,1 kPa (1 mbar)	1 kPa (10 mbar)	-1...+1 kPa (-10...+10 mbar)
3	0,42 kPa (4,2 mbar)	6,3 kPa (63 mbar)	-6,3 kPa...+6,3 kPa (-63...+63 mbar)
4	2,7 kPa (27 mbar)	41 kPa (410 mbar)	-41...+41 kPa (-410...+410 mbar)
5	20 kPa (200 mbar)	300 kPa (3000 mbar)	-300...+300 kPa (-3000...+3000 mbar)
6	145 kPa (1,45 bar)	2,2 MPa (22 bar)	-2,2...+2,2 MPa (-22...+22 bar)
7	1 MPa (10 bar)	15 MPa (150 bar)	-15...+15 MPa (-150...+150 bar)

Output	
S	4-20mA DC/HART® -protocol

Process connection			
D	M10,PN40 range 2/PN100 ranges 3 to 6,DIN19213 Teil 1.	H	M12,PN400 ranges 3, 4, 5 and 7,DIN 19213 Teil 2.
U	7/16-20 UNF,(PN400 ranges 3, 4, 5 and 7 only).	F	Screwed flange adapters,PN40 range 2 and PN100 ranges 3 to 6,DIN19213 Teil 1; PN250 range 7,DIN19213 Teil 2.
Z	Welded flange adapters,PN400 ranges 3 to 5 and 7,DIN19213. V Connection through hydraulic seal.		

Wetted material	Flanges	Diaphragm	Diaphragm coating
	Code Material	Code Material	Code Material
	2 AISI316L	2 AISI316L	(specify only when coated)
	3 Hast.C 276	(std, range codes 6 & 7)	
		3 Hast.C 276	
		7 CoNi alloy	9 gold/Rhodium
		(std, range codes 2 to 5)	

Fill fluid	S Silicone oil	G Inert oil
-------------------	-----------------------	--------------------

Housing type	
H	Housing with PLUG-connector, DIN43650, no display, inlet PG9
T	Housing with PLUG-connector, DIN43650, no display, inlet PG9, with manual adjust
M	Housing with junction box/terminal strip, no display, inlet M20x1,5
N	Housing with junction box/terminal strip, with display, inlet M20x1,5

Explosion proof	0 No explosion proof classification	1 EEx ia II C T4 (not Atex)
------------------------	--	------------------------------------

Process thread on flange adapter (only specify for type F)	Thread type	Thread size
	Code Type	Code Size
	R straight R thread	2 1/4
	N NPS thread	3 3/8
	P taper R thread	4 1/2
	T NPT thread	

Special size of electrical inlet		
N 1/2 NPT	G Pg13.5	P PLUG-connector DIN43650

Special features

Special electronics (specify only if housing connected with hose to sensing element)

- connecting cable with protection hose

L Hose protected with PTFE/AISI316 braiding, straight

K Hose protected with PTFE/AISI316 braiding, angle of 90°

Length of cable between sensing element and housing
(specify only if housing connected with cable to sensing element)

2 2 m cable **3** 3 m cable etc. (max. 20 m)

Mounting parts for remote electronics for Ø51 mm tube

0 No mounting parts **1** Mounting parts

Documentation

Calibration Certificate **AE** English

Installation and Operating Instructions **IE** English **IF** Finnish

Material Certificates

0 No material certificate

MC1 Raw materials certificate without appendixes, in accordance with SFS-EN 10204-2.1 (DIN 50049-2.1) standard

MC2 Raw materials certificate for wetted parts with appendixes, in accordance with SFS-EN 10204-2.2 (DIN 50049-2.2) standard

MC3 Raw materials certificate for wetted parts with appendixes, in accordance with SFS-EN 10204-3.1B (DIN 50049-3.1B) standard

We reserve the right for technical modifications without prior notice.
HART® is a registered trademark of HART Communication Foundation.
Viton® is the registered trademark of DuPont Down Elastomers.
Hastelloy® is the registered trademark of Haynes International.
Teflon® is the registered trademark of E.I. du Pont de Nemours & Co

