

SATRON VG Flush Mount Pressure Transmitter

BPLV700
December 17, 2004

SATRON VG pressure transmitter belongs to the series V transmitters which will have both analog and smart properties. SATRON VG is used for 0-4 kPa...0-25 MPa ranges. The transmitter communicates in a 2-wire system. In pressure measuring applications SATRON VG-transmitters are used for measuring the pressure of clean, sedimenting, crystallizing and sticking materials. The transmitter's sensor is piezoresistive. The rangeability is 25:1. The transmitter communicates digitally using the HART® protocol.



TECHNICAL SPECIFICATIONS

Measuring range and span

See Selection Chart.

Zero and Span adjustment

Zero elevation: Calibrated span is freely selectable on the specified range depending from the desired option. This can be made by using external control shafts (analog option), keyboard (display option) or HART®275 communicator.

Damping

- Time constant is continuously adjustable 0,01 to 60 s.

Temperature limits

Ambient: -30 to +80 °C

Process: -30 to +125/+200 °C

Shipping and storage: -40 to +80 °C.

Pressure limits Min. and max. process pressure: See the appended tables.

Volumetric displacement

< 0.5 mm³ /max. span

Output 2-wire (2W), 4-20 mA, user selectable for linear, square root, inverted signal or the transfer function (16 points) specified by the user

Supply voltage and permissible load

See the load capacity diagram;

- **Smart** (codes **S**, **D** and **R**)

4-20 mA output: 12 - 35 VDC.

Humidity limits

0-100 % RH; freezing of condensed water not allowed in reference pressure channels.

PERFORMANCE SPECIFICATIONS

Tested in accordance with IEC770:

Reference conditions, specified span, no range elevation, horizontal mounting; O-ring seals, AISI316L diaphragm, silicone oil fill.

Accuracy

±0.1 % of calibrated span

(span 1:1-7.5:1 /max.range).

On the measuring ranges 7.5:1-25:1:

$\pm[0.01+0.012 \times (\frac{\text{max. span}}{\text{calibrated span}})]\%$ of calibrated span

(incl. nonlinearity, hysteresis and repeatability)

Long-term stability

±0.1 % / max. span / year

¹⁾ Parts in contact with process medium

Temperature effect

- on **-20 to +80 °C range** (process temperature code **N**)

Zero and span error:

±0.15 % of max. span.

- on **0 to +200 °C range**, (process temperature code **H**)

Zero and span error:

±1 % of max. span, VG6 - VG8

±2 % of max. span, VG4 - VG5

Mounting position effect

Zero error < 0.32 kPa, which can be calibrated out.

Vibration effect (IEC 68-2-6: FC):

±0.1 % of measuring range/

2g/10 to 2000 Hz

4g/10 to 100 Hz

Power supply effect

< ±0.01 of calibrated span per volt

EMC-test standards

GENERIC EMISSION STANDARD:

EN 50081 - 2: 1993

Normative reference:

EN 55022:1987/class A

GENERIC IMMUNITY STANDARD:

EN 50082 - 2: 1995

Normative references:

EN 61000-4-2, -4, -5, -8, -11

ENV 50140, ENV 50204, ENV 50141

Insulation test voltage

500 V rms 50 Hz

CONSTRUCTION AND CALIBRATION

Materials

Diaphragm ¹⁾: AISI316L, Duplex (Wnr 1.4462), Hast. C22/276 or Tantalum.

Coupling ¹⁾: AISI316L, Duplex (Wnr 1.4462), Hast. C276 or Titanium.

Other sensing element materials:

AISI316, SIS 2343.

Filling fluid: Silicone oil, food oil or inert oil

Enclosure class IP66

Housing with PLUG connector,

housing type codes **H** and **T**

Housing: AISI316

Seals: Viton® and NBR

TEST jacks: MS358Sn/PVDF, protected with silicone rubber shield.

PLUG connector: PA6-GF30 jacket, Silicone rubber seal, AISI316 retaining screw.

Housing with junction box/terminal strip,

housing type codes **M** and **N**

Housing: AISI303/316; Seals: Nitrile

and Viton®; Nameplates: Polyester

Connection hose between sensing element and housing

Codes **L** and **K**:

PTFE hose with AISI316 braiding.

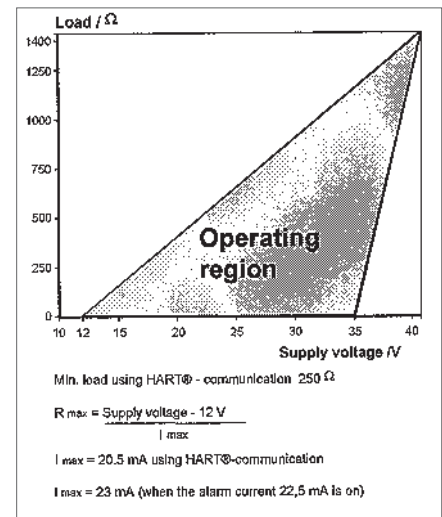

Pressure limits

Maximum process pressure, MPa

Transmitter type	Max. overload pressure	Pressure class
VG4	0.3	PN40
VG5	1.5	PN40
VG6	7.5	PN100
VG7	40.0	PN250
VG8	100.0	PN250

Minimum process pressure

T _{proc.} °C	Minimum pressure for different fill fluids (kPa, abs.)	
	DC200 100 cSt	Inert oil
20	5	8
40	8	10
80	16	28
120	21	53

SATRON VG Flush Mount Pressure Transmitter

BPLV700
December 14, 2004

Calibration

For customer-specified range with minimum damping. (If range is not specified, transmitter is calibrated for maximum range.)

Process connections

G1 connecting thread
Process couplings: See Selection Chart and installation instructions or technical specification: Couplings for Transmitters **G150**.

Electrical connections

Housing with PLUG connector, **H and T**:
PLUG connector, connector type DIN 43650 model AF; Pg9 gland for cable; wire gross-section 0.5 to 1.5 mm².

Housing with junction box/terminal strip, **M and N**:
M20x1.5, 1/2-NPT inlet; screw terminals for 0.5 to 2.5 mm² wires

Weight

Transmitter
- with housing type **H** and **T** : 0.7 kg
- with housing type **M** : 1.2 kg
- with housing type **N** : 1.3 kg

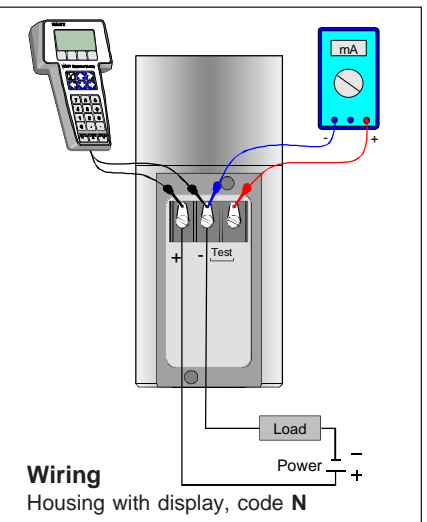
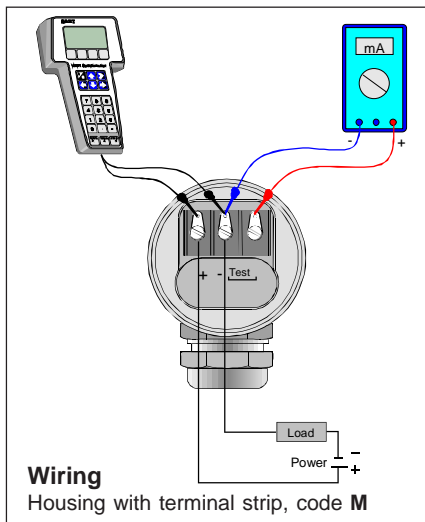
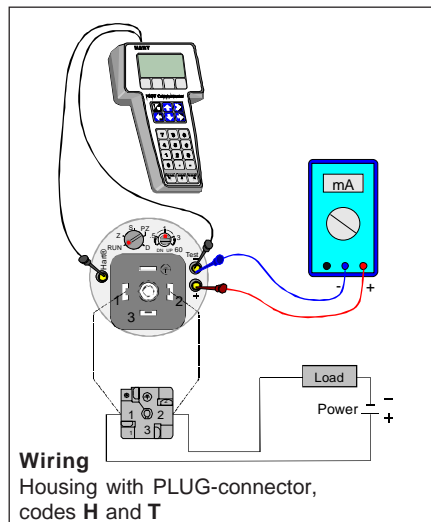
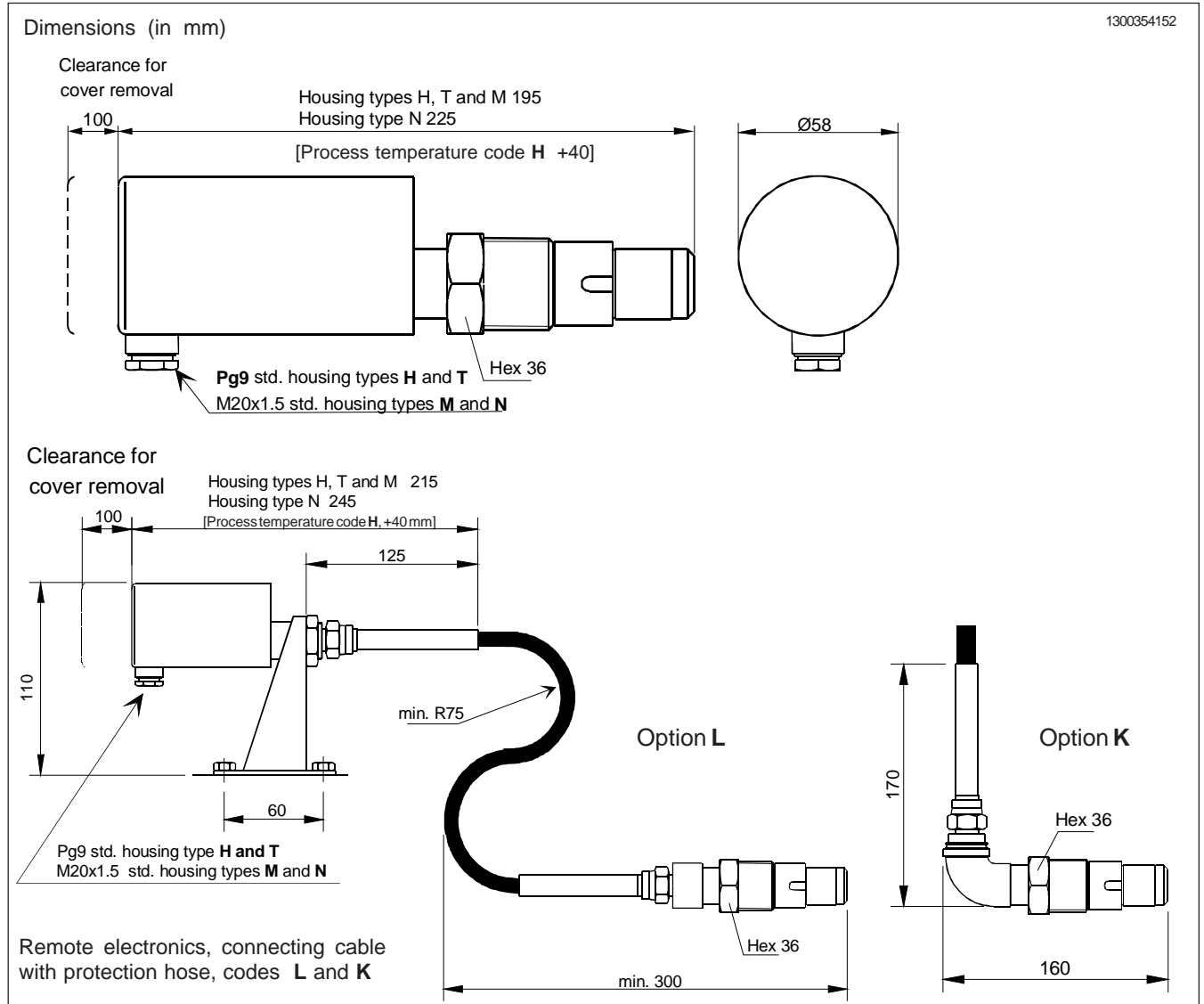

Couplings

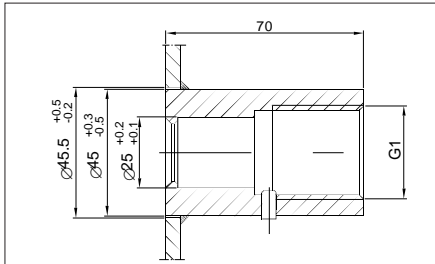

Standard coupling

Material: AISI316 L or Hastelloy C

Special couplings:

- G1 hygienic coupling, M548101
- G1/2A/G1 coupling, M546190
- G1/2A/G1 coupling with venting, M860280
- G1/2A/ G1 couplings with bracket:
 - G1/2A male, M546195
 - G1/2 female, M550393

Transmitter's process sealing

Three different options are available for the transmitter's process sealing:

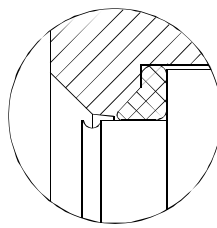

AISI316L diaphragm,
Viton O-ring
(code 1)

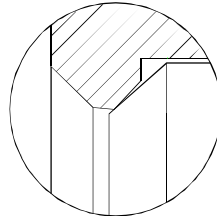

AISI316L diaphragm,
PTFE O-ring
(code 2)

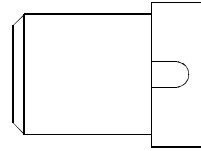

AISI316L, CoNi-, Duplex,
Hastelloy C276 or Tantalum
diaphragm, metal/metal taper
sealing
(diaphragm on sealing face)
(code 4)

Flanges:

Dimensions of flanged couplings, see the installation and setting-up instructions

PASVE™ mounting & service valve

All PASVE™ types are also available with pneumatic actuator, flushing and limit switches.

PASVE GF (NF)
(Flange type)

GP (NP)
(Welded
on pipe)

GC (NC)
(Welded
on container)

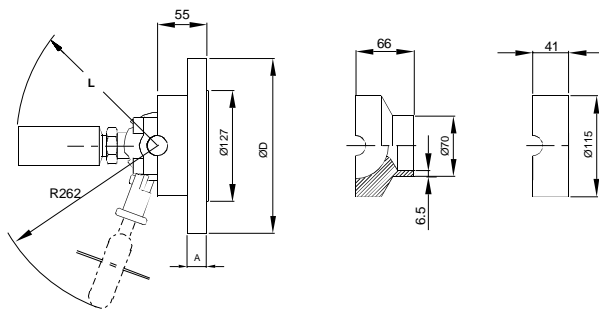

Process temperature limits, code H

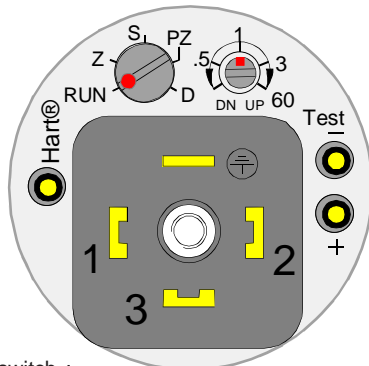
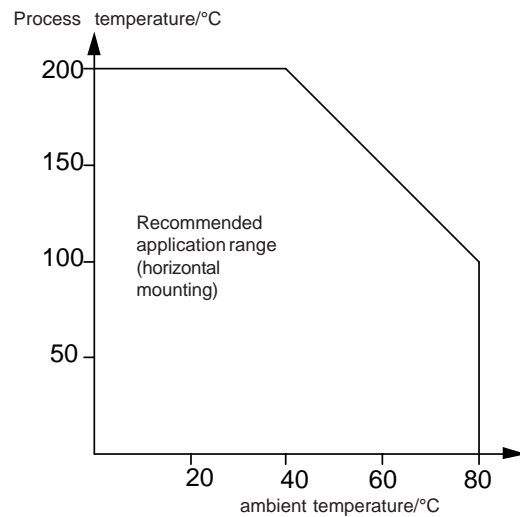

- Use of selector switch :
- RUN = working position
 - PZ = Process value zero
 - D = damping adjustment
 - S = Span adjustment
 - Z = Zero adjustment
 - DN = Down
 - UP = Up

Housing with PLUG-connector, housing code T

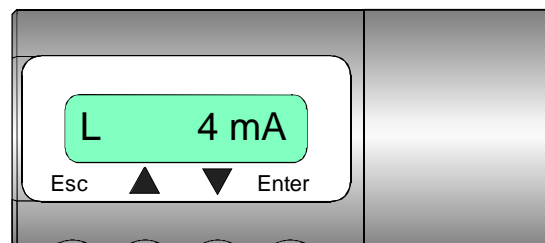

Keyboard :

- Esc = Press **Esc** move back towards the top of the main menu.
- ▲ = Use the **UP** arrow key to move up on the current menu level or to increase the selected parameter value.
- ▼ = Use the **DOWN** arrow key to move down on the current menu level or to decrease the selected parameter value.
- Enter = Press **ENTER** to move to a lower level in a menu or to accept a command or parameter value.

Housing with display, housing code N

Selection Chart

Adjustability	Span, min	Span, max	Measuring range
VG4	4 kPa (40 mbar)	100 kPa (1000 mbar)	-100...+100 kPa (-1000...1000 mbar)
VG5	26.5 kPa (265 mbar)	500 kPa (5000 mbar)	-100...+500 kPa (-1000...5000 mbar)
VG6	0.145 MPa (1.45 bar)	3 MPa (30 bar)	-0.1...+3 MPa (-1...30 bar)
VGA6	0.145 MPa (1.45 bar)	3 MPa (30 bar)	0...+3 MPa (0...30 bar), abs.
VG7	1 MPa (10 bar)	15 MPa (150 bar)	0...+15 MPa (0...150 bar), abs.
VG8	6,7 MPa (67 bar)	25 MPa (250 bar)	-0,1...+25 MPa (-1...250bar)

Output S 4-20mA DC/HART® -protocol

Process seal 1 O-ring (Viton®) 2 O-ring (PTFE) 4 metal/metal taper

Wetted materials

2 AISI316L 3 Hast. C 276 (*) 5 Tantalum (*) 7 CoNi-alloy (not range 4) (*) 8 Duplex (Wnr 1.4462) (*)

Fill fluid S Silicon oil G Inert oil A Food and beverage special (Neobee M20)

Housing type

H Housing with PLUG-connector, DIN43650, no display, inlet PG9
T Housing with PLUG-connector and with manual adjust, DIN43650, no display, inlet PG9
M Housing with junction box/terminal strip, no display, inlet M20x1,5
N Housing with junction box/terminal strip, with display, inlet M20x1,5

Explosion proof 0 No explosion proof classification 1 Ex ia IIC T4 (not Atex)

Process temperature limits N -30 ... +125 °C H 0 ... +200 °C



Process coupling

0 No coupling E Hygienic coupling
 G Standard coupling

Material

2 AISI316L
 3 Hast.C276
 6 Titanium
 8 Duplex

PASVET™ mounting valve, specify separately in the order
 Specify special couplings separately in the order

Special size of electrical inlet

N 1/2 NPT G Pg13.5 P PLUG-connector DIN43650

Special features

Remote electronics (specify only if housing connected with cable to sensing element)

- connecting cable with protection hose

L Hose protected with PTFE/AISI316 braiding, straight
 K Hose protected with PTFE/AISI316 braiding, angle of 90°

Length of connection cable between sensing element and housing

2 2 m cable
 3 3 m cable etc. (max. 10 m)

Mounting parts for remote electronics for Ø 51 mm tube

0 No mounting parts 1 Mounting parts

Documentation

Calibration certificate AE English

Installation and operating instructions IE English IF Finnish

Material certificates

0 No material certificate
MC1 Raw material certificate without appendixes, in accordance with SFS-EN 10204-2.1 (DIN 50049-2.1) standard
MC2 Raw material certificate for wetted parts, in accordance with SFS-EN 10204-2.2 (DIN 50049-2.2) standard
MC3 Raw material certificate for wetted parts, in accordance with SFS-EN 10204-3.1 B (DIN 50049-3.1 B) standard

(*)= only process seal code 4

We reserve the right for technical modifications without prior notice.
 HART® is a registered trademark of HART Communication Foundation.
 Pasve™ is a trademark of Satron Instruments Inc.
 Hastelloy® is the registered trademark of Haynes International.
 Teflon® is the registered trademark of E.I. du Pont de Nemours & Co

