

SITRANS P measuring instruments for pressure

Transmitters for pressure, absolute pressure, differential pressure, flow and level

DS III series

Overview



SITRANS P pressure transmitters, DS III series, are digital pressure transmitters featuring extensive user-friendliness and high accuracy. Parameterization is performed using input keys or by means of HART communication.

Extensive functionality enables the pressure transmitter to be precisely adapted to the plant's requirements. Operation is very simple in spite of the numerous setting options.

Transmitters with type of protection "Intrinsic safety" and "Explosion-proof" may be installed within potentially explosive atmospheres (zone 1) or in zone 0. The transmitters are provided with an EC type examination certificate and comply with the corresponding harmonized European standards (ATEX).

The transmitters can be equipped with various designs of remote seals for special applications such as the measurement of highly viscous substances.

Various versions of the DS III pressure transmitters are available for measuring:

- Pressure
- Absolute pressure
- For differential pressure transmitters
- Level
- Volume
- Volume flow
- Mass flow

Benefits

- High quality and long life
- High reliability even under extreme chemical and mechanical loads
- Extensive diagnosis and simulation functions
- Separate replacement of measuring cell and electronics without recalibration
- Minimum conformity error
- Small long-term drift
- Wetted parts made of high-grade materials (e.g. stainless steel, Hastelloy, gold, Monel, tantalum)
- Measuring range 1 mbar ... 400 bar
- High measuring accuracy
- Parameterization using input keys and HART communication

Application

The pressure transmitters of the DS III series, can be used in industrial areas with extreme chemical and mechanical loads. Electromagnetic compatibility in the range 10 kHz to 1 GHz makes the DS III pressure transmitters suitable for locations with high electromagnetic emissions.

Pressure transmitters with type of protection "Intrinsic safety" and "Explosion-proof" may be installed within potentially explosive atmospheres (zone 1) or in zone 0. The pressure transmitters are provided with an EC type examination certificate and comply with the corresponding harmonized European standards (ATEX).

Pressure transmitters with the type of protection "Intrinsic safety" for use in zone 0 may be operated with power supply units of category "ia" and "ib".

The transmitters can be equipped with various designs of remote seals for special applications such as the measurement of highly viscous substances.

The pressure transmitters can be programmed locally using three input keys or externally through HART communication.

Pressure transmitters for pressure

Measured variable: Pressure of aggressive and non-aggressive gases, vapors and liquids.

Nominal measuring ranges: 1 ... 400 bar (14.5 ... 5802 psi)

Pressure transmitters for absolute pressure

Measured variable: Absolute pressure of aggressive and non-aggressive gases, vapors and liquids.

Nominal measuring ranges: 250 mbar ... 100 bar (3.63 ... 1450 psi)

There are two series:

- Pressure series
- Differential pressure series

Pressure transmitters for differential pressure and flow

Measured variables:

- Differential pressure
- Small positive or negative pressure

SITRANS P measuring instruments for pressure

Transmitters for pressure, absolute pressure, differential pressure, flow and level

DS III series

- Flow $q \sim \sqrt{\Delta p}$ (together with a primary differential pressure device)

Nominal measuring ranges: 20 mbar ... 30 bar (0.29 ... 435 psi)

Pressure transmitters for level

Measured variable: Level of aggressive and non-aggressive liquids in open and closed vessels.

Nominal measuring ranges: 250 mbar ... 5 bar (3.63 ... 72.5 psi)

Nominal diameter of the mounting flange:

- DN 80 or DN 100
- 3 inch or 4 inch

In the case of level measurements in open containers, the low-pressure connection of the measuring cell remains open (measurement "compared to atmospheric").

In the case of measurements in closed containers, the lower-pressure connection has to be connected to the container in order to compensate the static pressure.

The wetted parts are constructed from a variety of materials depending on the degree of corrosion resistance required.

Design

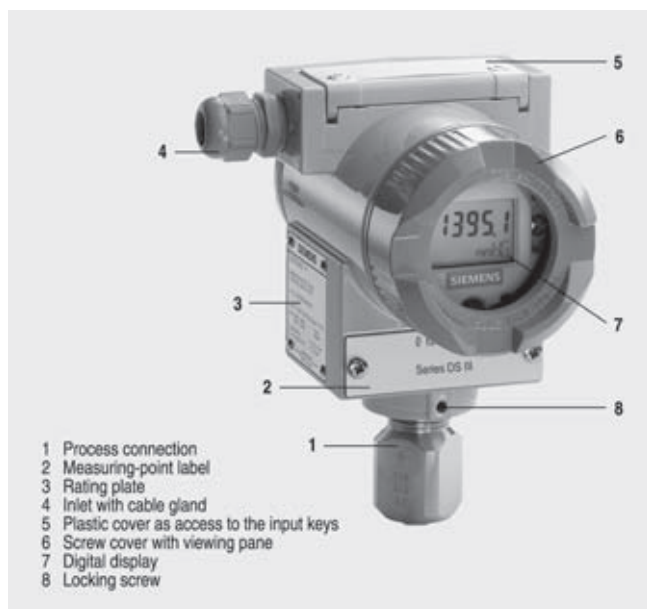

Front view

The transmitter consists of various components depending on the order. The possible versions are listed in the ordering information. The components described below are the same for all transmitters.

The rating plate (3, Figure "Front view") with the Order No. is located on the side of the housing. The specified number together with the ordering information provide details on the optional design details and on the possible measuring range (physical properties of built-in sensor element).

The approval label is located on the opposite side.

The housing is made of die-cast aluminium or stainless steel precision casting. A round cover is screwed on at the front and rear of the housing. The front cover (6) can be fitted with a viewing pane so that the measured values can be read directly on the digital display. The inlet (4) for the electrical connection is located either on the left or right side. The unused opening on the opposite side is sealed by a blanking plug. The protective earth connection is located on the rear of the housing.

The electrical connections for the power supply and screen are accessible by unscrewing the rear cover. The bottom part of the housing contains the measuring cell with process connection (1). The measuring cell is protected from rotating by a locking screw (8). As the result of this modular design, the measuring cell and the electronics can be replaced separately from each other. The set parameter data are retained.

At the top of the housing is a plastic cover (5), under which the input keys can be found.

Function

Mode of operation of the electronics

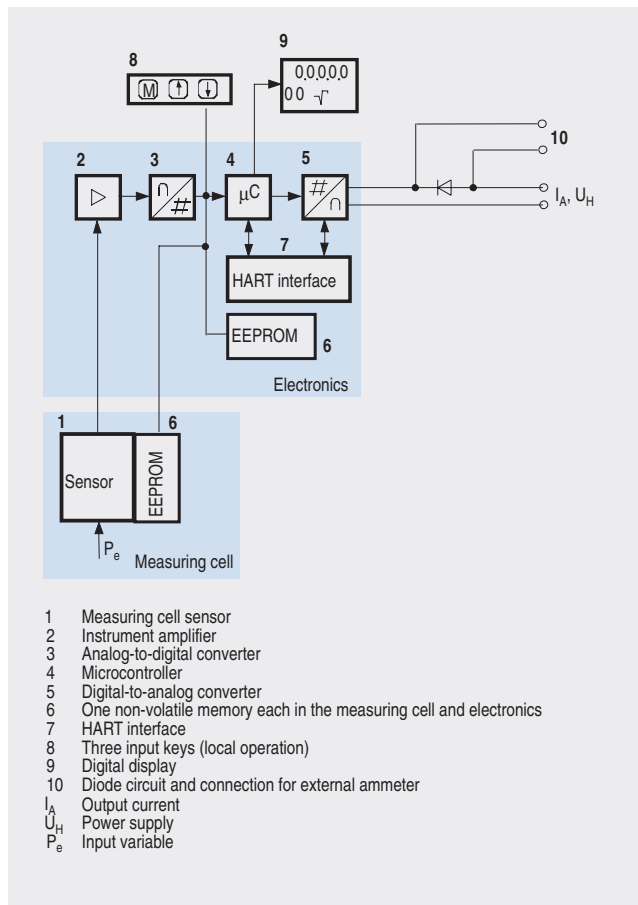

Function diagram of the electronics

The bridge output voltage created by the sensor (1, Figure "Function diagram of the electronics") is amplified by the instrument amplifier (2) and digitized in the analog-to-digital converter (3). The digital information is evaluated in a microcontroller, its linearity and temperature response corrected, and converted in a digital-to-analog converter (5) into an output current of 4 to 20 mA.

The diode circuit (10) protects against incorrect polarity.

The data specific to the measuring cell, the electronics data, and the parameter data are stored in the two non-volatile memories (6). The one memory is coupled to the measuring cell, the other to the electronics. As the result of this modular design, the electronics and the measuring cell can be replaced separately from each other.

Using the 3 input keys (8) you can parameterize the pressure transmitter directly at the point of measurement. The input keys can also be used to control the view of the results, the error messages and the operating modes on the digital display (9).

SITRANS P measuring instruments for pressure

Transmitters for pressure, absolute pressure, differential pressure, flow and level

DS III series

2

The HART modem (7) permits parameterization using a protocol according to the HART specification.

The pressure transmitters with spans ≤ 63 bar measure the input pressure compared to atmosphere, transmitters with spans ≥ 160 bar compared to vacuum.

Mode of operation of the measuring cells

Measuring cell for pressure

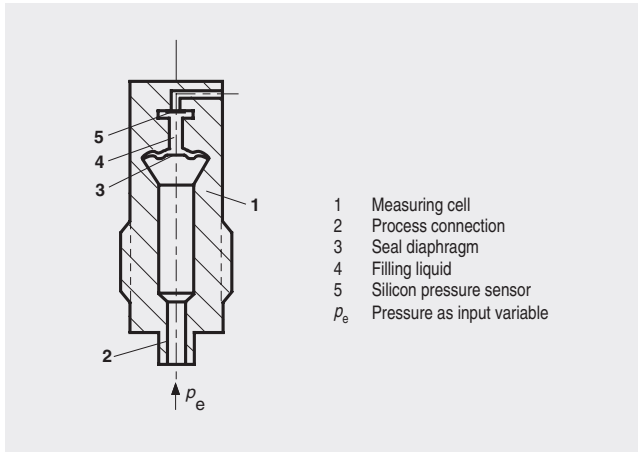

Measuring cell for pressure, functional diagram

The pressure p_e is applied through the process connection (2, Figure "Measuring cell for pressure, functional diagram") to the measuring cell (1). This pressure is subsequently transmitted further through the seal diaphragm (3) and the filling liquid (4) to the silicon pressure sensor (5) whose measuring diaphragm is then flexed. The resistance of the four piezo-resistors fitted in the diaphragm in a bridge circuit thus changes. This change in resistance results in a bridge output voltage proportional to the input pressure.

Measuring cell for absolute pressure from pressure series

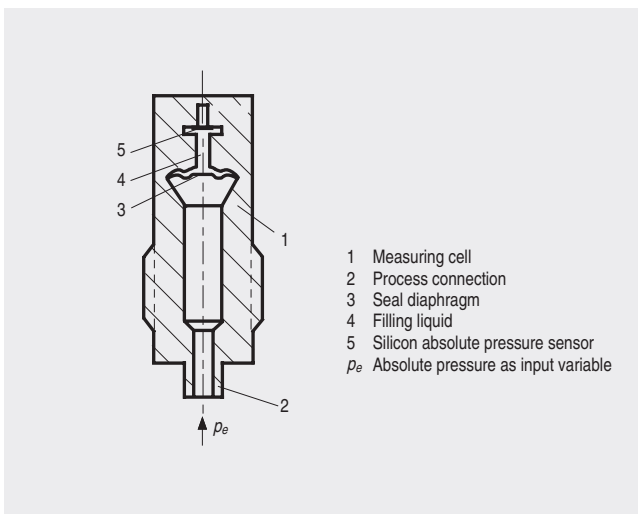

Measuring cell for absolute pressure from the pressure series, functional diagram

The absolute pressure p_e is transmitted through the seal diaphragm (3, Figure "Measuring cell for absolute pressure from pressure series, functional diagram") and the filling liquid (4) to the silicon absolute pressure sensor (5) whose measuring diaphragm is then flexed. The resistance of the four piezo-resistors fitted in the diaphragm in a bridge circuit thus changes. This change in resistance results in a bridge output voltage proportional to the input pressure.

Measuring cell for absolute pressure from differential pressure series

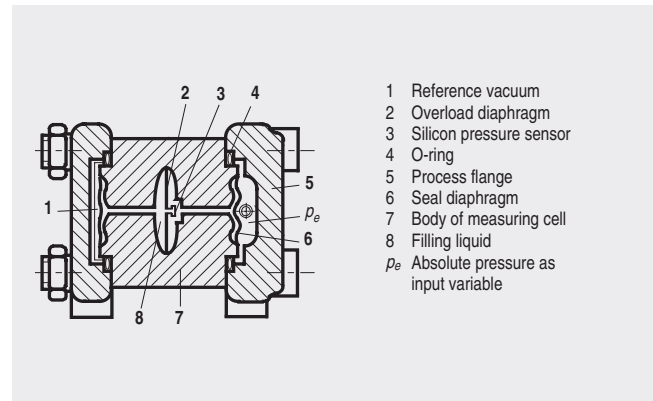

Measuring cell for absolute pressure from differential pressure series, functional diagram

The input pressure p_e is transmitted through the seal diaphragm (6, Figure "Measuring cell for absolute pressure from differential pressure series, functional diagram") and the filling liquid (8) to the silicon pressure sensor (3).

The difference in pressure between the input pressure p_e and the reference vacuum (1) on the low-pressure side of the measuring cell flexes the measuring diaphragm. The resistance of the four piezo-resistors fitted in the diaphragm in a bridge circuit thus changes. This change in resistance results in a bridge output voltage proportional to the absolute pressure.

An overload diaphragm is installed to provide protection from overloads. If the measuring limits are exceeded, the overload diaphragm (2) is flexed until the seal diaphragm rests on the body of the measuring cell (7), thus protecting the silicon pressure sensor from overloads.

Measuring cell for differential pressure and flow

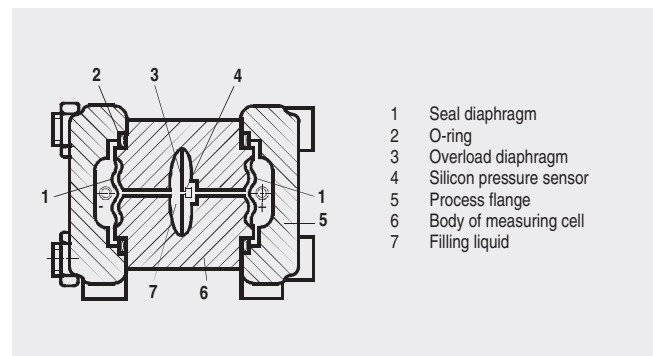

Measuring cell for differential pressure and flow, functional diagram

The differential pressure is transmitted through the seal diaphragms (1, Figure "Measuring cell for differential pressure and flow, functional diagram") and the filling liquid (7) to the silicon pressure sensor (4).

The measuring diaphragm is flexed by the applied differential pressure. The resistance of the four piezo-resistors fitted in the diaphragm in a bridge circuit thus changes. This change in resistance results in a bridge output voltage proportional to the absolute pressure.

An overload diaphragm is installed to provide protection from overloads. If the measuring limits are exceeded, the overload diaphragm (2) is flexed until the seal diaphragm rests on the body of the measuring cell (7), thus protecting the silicon pressure sensor from overloads.

SITRANS P measuring instruments for pressure

Transmitters for pressure, absolute pressure, differential pressure, flow and level

DS III series

Measuring cell for level

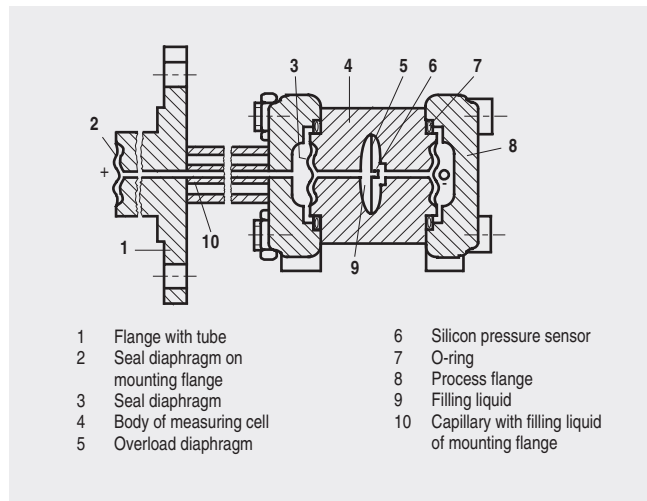

Measuring cell for level, functional diagram

The input pressure (hydrostatic pressure) acts hydraulically on the measuring cell through the seal diaphragm on the mounting flange (2, Figure "Measuring cell for level, functional diagram"). This differential pressure is subsequently transmitted further through the measuring cell (3) and the filling liquid (9) to the silicon pressure sensor (6) whose measuring diaphragm is then flexed.

The resistance of the four piezo-resistors fitted in the diaphragm in a bridge circuit thus changes. This change in resistance results in a bridge output voltage proportional to the differential pressure.

An overload diaphragm is installed to provide protection from overloads. If the measuring limits are exceeded, the overload diaphragm (2) is flexed until the seal diaphragm rests on the body of the measuring cell (7), thus protecting the silicon pressure sensor from overloads.

Parameterization

Depending on the version, there are different possibilities for parameterizing the pressure transmitter and for setting or scanning the parameters.

Adjustable parameters

Parameters	Input keys	HART communication
Start of scale	x	x
Full-scale value	x	x
Electrical damping	x	x
Start-of-scale value without application of a pressure ("Blind setting")	x	x
End-of-scale value without application of a pressure ("Blind setting")	x	x
Zero adjustment	x	x
Current transmitter	x	x
Fault current	x	x
Disabling of keys, write protection	x	x ¹⁾
Type of dimension and actual dimension	x	x
Characteristic (linear / square-rooted)	x ²⁾	x ²⁾
Input of characteristic		x
Freely-programmable LCD		x
Diagnostics functions		x

¹⁾ Cancel apart from write protection

²⁾ Only differential pressure

The following diagnostics functions are available using HART communication:

- Zero correction display
- Event counter
- Limit transmitter
- Saturation alarm
- Slave pointer
- Simulation functions
- Maintenance timer

Parameterization using the input keys (local operation)

With the input keys you can easily set the most important parameters without any additional equipment.

Parameterization using HART communication

Parameterization using HART communication is performed with a HART communicator or a PC.

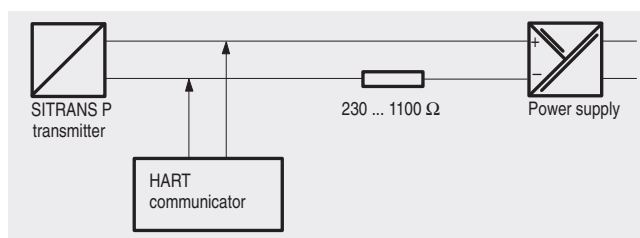

HART communication between a HART communicator and a pressure transmitter

When parameterizing with the HART communicator, the connection is made directly to the 2-wire system.

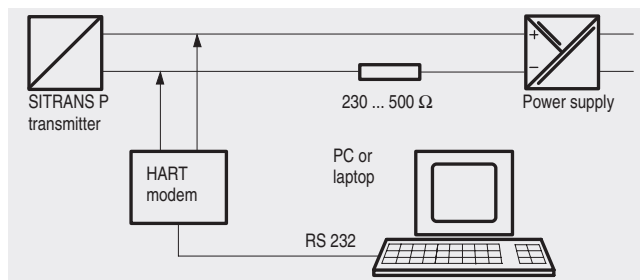

HART communication between a PC communicator and a pressure transmitter

When parameterizing with a PC, the connection is made through a HART modem.

The signals needed for communication in conformity with the HART 5.x or 6.x protocols are superimposed on the output current using the Frequency Shift Keying (FSK) method.

Physical dimensions available for the display

Physical variable	Physical dimensions
Pressure (setting can also be made in the factory)	Pa, MPa, kPa, hPa, bar, mbar, torr, atm, psi, g/cm ² , kg/cm ² , inH ₂ O, inH ₂ O (4 °C), mmH ₂ O, ftH ₂ O, inHg, mmHg
Level (height data)	m, cm, mm, ft, in
Volume	m ³ , dm ³ , hl, yd ³ , ft ³ , in ³ , US gallon, Imp. gallon, bushel, barrel, barrel liquid
Volume flow	m ³ /d, m ³ /h, m ³ /s, l/min, l/s, ft ³ /d, ft ³ /min, ft ³ /s, US gallon/min, US gallon/s
Mass flow	t/d, t/h, t/min, kg/d, kg/h, kg/min, kg/s, g/d, g/h, g/min, g/s, lb/d, lb/h, lb/min, lb/s, LTon/d, LTon/h, STon/d, STon/h, STon/min
Total mass flow	t, kg, g, lb, oz, LTon, STon
Temperature	K, °C, °F, °R
Miscellaneous	%, mA

SITRANS P measuring instruments for pressure

Transmitters for pressure, absolute pressure, differential pressure, flow and level

DS III series for pressure

2

Technical specifications

SITRANS P pressure transmitters, DS III series, for pressure

Input

Measured variable	Pressure
Span (continuously adjustable)	Maximum working pressure
• 0.01 ... 1 bar (0.145 ... 14.5 psi)	6 bar (87 psi)
• 0.04 ... 4 bar (0.58 ... 58 psi)	10 bar (145 psi)
• 0.16 ... 16 bar (2.32 ... 232 psi)	32 bar (464 psi)
• 0.6 ... 63 bar (9.14 ... 914 psi)	100 bar (1450 psi)
• 1.6 ... 160 bar (23.2 ... 2320 psi)	250 bar (3626 psi)
• 4.0 ... 400 bar (58 ... 5802 psi)	500 bar (7252 psi)
Lower measuring limit	
• Measuring cell with silicone oil filling	30 mark (0.435 psi) absolute
Upper measuring limit	100% of max. span (max. 160 bar (2320 psi) with oxygen measurement and inert liquid)

Output

Output signal	4 ... 20 mA
---------------	-------------

Measuring accuracy

Reference conditions	Increasing characteristic Start-of-scale value 0 bar Stainless steel seal diaphragm Silicone oil filling Room temperature (25 °C (77 °C)) r: Span ratio (r = max. span / set span)
Error in measurement and fixed-point setting (including hysteresis and repeatability)	
• Linear characteristic	
- $r \leq 10$	$\leq (0.0029 \cdot r + 0.071)\%$
- $10 < r \leq 30$	$\leq (0.0045 \cdot r + 0.071)\%$
- $30 < r \leq 100$	$\leq (0.005 \cdot r + 0.05)\%$
Influence of ambient temperature	
• With -10 ... +60 °C (14 ... 140 °F)	$\leq (0.08 \cdot r + 0.1)\%$
• With -40 ... -10 °C and +60 °C ... +85 °C (-40 ... +14 and 140 ... 185 °F)	$\leq (0.1 \cdot r + 0.15)\% / 10 \text{ K}$ ($\leq (0.1 \cdot r + 0.15)\% / 18 \text{ °F}$)

Rated conditions

Degree of protection (to EN 60529)	IP65
Process temperature	
• Measuring cell with silicone oil filling	-40 ... +100 °C (-40 ... +212 °F)
• Measuring cell with inert filling liquid	-20 ... +100 °C (-4 ... +212 °F)
• In conjunction with dust explosion protection	-20 ... +60 °C (-4 ... +140 °F)

Design

Weight (without options)	≈ 1.5 kg (≈ 3.3 lb)
Wetted parts materials	
• Connection shank	Stainless steel, mat. No. 1.4404/316L or Hastelloy C4, mat. No. 2.4610
• Seal diaphragm	Stainless steel, mat. No. 1.4404/316L or Hastelloy C276, mat. No. 2.4819
Measuring cell filling	Silicone oil or inert filling liquid (max. 160 bar (2320 psi) with oxygen measurement)

Process connection	Connection shank G $\frac{1}{2}$ A to DIN EN 837-1, female thread $\frac{1}{2}$ -14 NPT or oval flange (PN 160 (MWP 2320)) with mounting thread M10 or $\frac{1}{16}$ -20 UNF to EN 61518
--------------------	---

Power supply U_H

Terminal voltage on transmitter	10.5 ... 45 V DC 10.5 ... 30 V DC in intrinsically-safe mode
---------------------------------	---

Certificates and approvals

Classification according to pressure equipment directive (DRGL 97/23/EC)	For gases of fluid group 1 and liquids of fluid group 1; complies with requirements of article 3, paragraph 3 (sound engineering practice)
Explosion protection	
• Intrinsic safety "i"	PTB 99 ATEX 2122
- Identification	Ex II 1/2 G EEx ia/ib IIB/IIC T6
- Permissible ambient temperature	-40 ... +85 °C (-40 ... +185 °F) temperature class T4; -40 ... +70 °C (-40 ... +158 °F) temperature class T5; -40 ... +60 °C (-40 ... +140 °F) temperature class T6
- Connection	To certified intrinsically-safe circuits with maximum values: $U_i = 30 \text{ V}$, $I_i = 100 \text{ mA}$, $P_i = 750 \text{ mW}$; $R_i = 300 \Omega$
- Effective internal inductance/capacitance	$L_i = 0.4 \text{ mH}$, $C_i = 6 \text{ nF}$
• Explosion-proof "d"	PTB 99 ATEX 1160
- Identification	Ex II 1/2 G EEx d IIC T4/T6
- Permissible ambient temperature	-40 ... +85 °C (-40 ... +185 °F) temperature class T4; -40 ... +60 °C (-40 ... +140 °F) temperature class T6
- Connection	To circuits with values: $U_H = 10.5 \dots 45 \text{ V DC}$
• Dust explosion protection for zone 20	PTB 01 ATEX 2055
- Identification	Ex II 1 D IP65 T 120 °C Ex II 1/2 D IP65 T 120 °C
- Permissible ambient temperature	-40 ... +85 °C (-40 ... +185 °F)
- Max. surface temperature	120 °C (248 °F)
- Connection	To certified intrinsically-safe circuits with maximum values: $U_i = 30 \text{ V}$, $I_i = 100 \text{ mA}$, $P_i = 750 \text{ mW}$, $R_i = 300 \Omega$
- Effective internal inductance/capacitance	$L_i = 0.4 \text{ mH}$, $C_i = 6 \text{ nF}$
• Dust explosion protection for zone 21/22	PTB 01 ATEX 2055
- Identification	Ex II 2 D IP65 T 120 °C
- Connection	To circuits with values: $U_H = 10.5 \dots 45 \text{ V DC}$; $P_{\text{max}} = 1.2 \text{ W}$
• Type of protection "n" (zone 2)	TÜV 01 ATEX 1696 X
- Identification	Ex II 3 G EEx nA L IIC T4/T5/T6
• Explosion protection to FM	Certificate of Compliance 3008490
- Identification (XP/DIP) or (IS); (NI)	CL I, DIV 1, GP ABCD T4...T6; CL II, DIV 1, GP EFG; CL III; CL I, ZN 0/1 AEx ia IIC T4...T6; CL I, DIV 2, GP ABCD T4...T6; CL II, DIV 2, GP FG; CL III

SITRANS P measuring instruments for pressure

Transmitters for pressure, absolute pressure, differential pressure, flow and level

DS III series for pressure

- Explosion protection to CSA Certificate of Compliance 1153651
- Identification (XP/DIP) or (IS) CL I, DIV 1, GP ABCD T4...T6; CL II, DIV 1, GP EFG; CL III; Ex ia IIC T4...T6; CL I, DIV 2, GP ABCD T4...T6; CL II, DIV 2, GP FG; CL III

Dimensional drawings

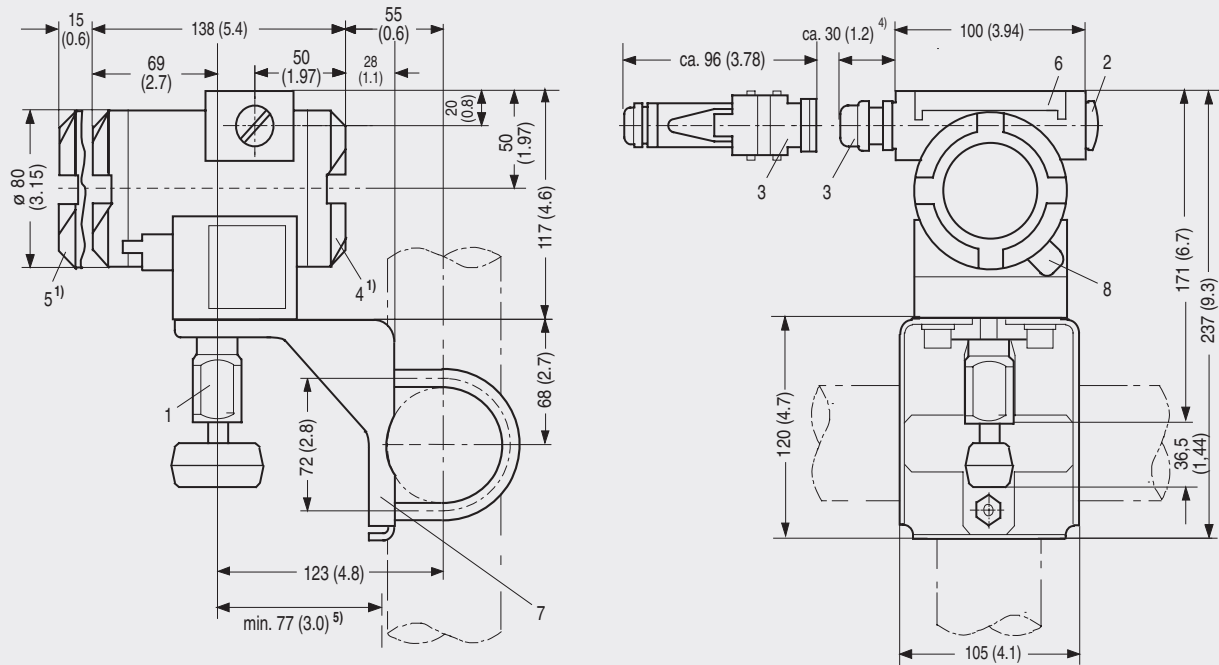

- 1 Process connection:
 - 1/2-14 NPT,
 - connection shank G1/2A or
 - oval flange
- 2 Blanking plug
- 3 Electrical connection:
 - screwed gland Pg 13,5 (adapter)^{2) 3)},
 - screwed gland M20x1,5³⁾,
 - screwed gland 1/2-14 NPT or
 - Han 7D/ Han 8U plug^{2) 3)}
- 4 Terminal side
- 5 Electronics side, digital display (longer overall length for cover with window)
- 6 Protective cover over keys
- 7 Mounting bracket (option)
- 8 Screw cover - safety bracket (only for type of protection "Explosion-proof enclosure", not shown in the drawing)

- 1) Allow approx. 20 mm (0.79 inch) thread length to permit unscrewing
- 2) Not with type of protection "explosion-proof enclosure"
- 3) Not with type of protection "FM + CSA [is + xp]"
- 4) 45 mm (1.8 inch) for Pg 13,5 with adapter
- 5) Minimum distance for rotation

SITRANS P pressure transmitters, DS III series for pressure, dimensional drawing, dimensions in mm (inch)

SITRANS P measuring instruments for pressure

Transmitters for pressure, absolute pressure, differential pressure, flow and level

DS III series for pressure

2

Selection and Ordering data		Order No.
SITRANS P pressure transmitter, DS III series, for pressure 2-wire system		7 MF 4 0 3 3 -
Measuring cell filling	Measuring cell cleaning	
Silicone oil	Standard	1
Inert liquid ¹⁾	Grease-free	3
Measured span		
0.01 ... 1 bar	(0.15 ... 14.5 psi)	B
0.04 ... 4 bar	(0.58 ... 58 psi)	C
0.16 ... 16 bar	(2.32 ... 232 psi)	D
0.63 ... 63 bar	(9.14 ... 914 psi)	E
1.6 ... 160 bar	(23.2 ... 2320 psi)	F
4.0 ... 400 bar	(58.0 ... 5802 psi)	G
Wetted parts materials		
Seal diaphragm	Process connection	
Stainless steel	Stainless steel	A
Hastelloy	Stainless steel	B
Hastelloy	Hastelloy	C
Version as diaphragm seal		Y 0
Process connection		
• Connection shank G½B to EN 837-1		0
• Female thread ½-14 NPT		1
• Oval flange made of stainless steel, max. span 160 bar (2320 psi)		
- Mounting thread 7/16-20 UNF to EN 61518		2
- Mounting thread M10 to DIN 19213		3
Non-wetted parts materials		
• Housing made of die-cast aluminium		0
• Housing stainless steel precision casting		3
Design		
• Standard design		1
• International version, English label inscriptions, documentation in 5 languages on CD		2
Explosion protection		
• without		A
• with ATEX, Type of protection:		
- "Intrinsic safety (EEx ia)"		B
- "Explosion-proof (EEx d)" ²⁾		D
• "Intrinsic safety and explosion-proof enclosure (EEx ia + EEx d)" ³⁾		P
- "n (zone 2)"		E
- "Intrinsic safety, explosion-proof enclosure and dust explosion protection (EEx ia + EEx d + zone 1D/2D)" ³⁾		R
• with FM + CSA, Type of protection:		
- "Intrinsic safety and explosion-proof (is + xp)" ²⁾		NC
Electrical connection / cable inlet		
• Screwed gland Pg 13.5 (adapter) ⁴⁾		A
• Screwed gland M20x1.5		B
• Screwed gland ½-14 NPT		C
• Han 7D plug (plastic housing) incl. mating connector ⁴⁾		D
Display		
• without (digital indicator hidden, setting: mA)		1
• with visible digital indicator, setting: mA		6
• with customer-specific digital indicator (setting as specified, Order code "Y21" or "Y22" required)		7

- 1) For oxygen application, add Order code E10.
- 2) Without cable gland, with blanking plug
- 3) With enclosed cable gland EEx ia and blanking plug
- 4) Not together with type of protection "Explosion-proof"

▶ Available ex stock

Power supply units see "SITRANS I power supply units and input isolators".

Included in delivery of the device:

- Brief instructions (Leporello)
- CD-ROM with detailed documentation

SITRANS P measuring instruments for pressure

Transmitters for pressure, absolute pressure, differential pressure, flow and level

DS III series for pressure

2

Further designs	Order code	Additional data	Order code
Please add "-Z" to Order No. and specify Order code.		Please add "-Z" to Order No. and specify Order code.	
Pressure transmitter with mounting bracket made of:		Measuring range to be set	Y01
• Steel	A01	specify in plain text:	
• Stainless steel	A02	Y01: ... to ... mbar, bar, kPa, MPa, psi	
Plug		Measuring point number/identification	Y15
• Han 7D (metal, gray)	A30	max. 16 characters, specify in plain text:	
• Han 8U (instead of Han 7D)	A31	Y15:	
Rating plate inscription		Measuring point text	Y16
(instead of German)		max. 27 characters, specify in plain text:	
• English	B11	Y16:	
• French	B12	Entry of HART address (TAG)	Y17
• Spanish	B13	max. 8 characters, specify in plain text:	
• Italian	B14	Y17:	
English rating plate	B21	Setting of pressure indicator in pressure units	Y21
Pressure units in inH ₂ O or psi		specify in plain text (standard setting: mA):	
Manufacturer's test certificate M	C11	Y21: mbar, bar, kPa, MPa, psi, ...	
(calibration certificate)		Note:	
to DIN 55350, Part 18 and to ISO 8402		The following pressure units can be selected:	
Acceptance test certificate B	C12	bar, mbar, mm H ₂ O [*] , inH ₂ O [*] , ftH ₂ O [*] , mmHG, inHG,	
to EN 10204-3.1.B		psi, Pa, kPa, MPa, g/cm ² , kg/cm ² , mA, Torr, ATM or %	
Factory certificate	C14	*) Reference temperature 20 °C	
to EN 10204-2.2		Setting of pressure indicator in non-pressure units	Y22 + Y01
Certificate "Functional Safety (SIL)"	C20	specify in plain text:	
Setting of upper limit of output signal to 22.0 mA	D05	Y22: up to l/min, m ³ /h, m, USgpm, ...	
Acid gas version to NACE	D07	(specification of measuring range in pressure units	
(only together with seal diaphragm made of Hastelloy)		"Y01" is essential, unit with max. 5 characters)	
Type of protection IP68	D12	Only the settings for "Y01", "Y21", "Y22" and "D05" can be made in the factory	
(not together with Han 7D / Han 8U plug,		Ordering example	
Pg 13.5 screwed gland)	D27	Item line: 7MF4033-1EA00-1AA7-Z	
Digital indicator along side the input keys		B line: A01 + Y01 + Y21	
(only together with the devices 7MF4033-....0-.A.6		C line: Y01: 10 ... 20 bar (145 ... 290 psi)	
or -.A.7-Z, Y21 or Y22 + Y01)	E01	C line: Y21: bar (psi)	
Use in or at zone 1D/2D			
(only together with type of protection "Intrinsic safety	E02		
(EEx ia)*)			
Use at zone 0	E10		
(only together with type of protection "Intrinsic safety			
(EEx ia)*)			
Oxygen application			
(max. 160 bar (2320 psi) with oxygen measurement			
and inert liquid)			

SITRANS P measuring instruments for pressure

Transmitters for pressure, absolute pressure, differential pressure, flow and level

DS III series for absolute pressure (from pressure series)

2

Technical specifications

SITRANS P pressure transmitters, DS III series for absolute pressure, from the pressure series

Input

Measured variable	Absolute pressure
Span	Maximum working pressure
• 8.3 ... 250 mbar (0.12 ... 3.6 psi)	6 bar (87 psi)
• 43 ... 1300 mbar (0.62 ... 18.9 psi)	10 bar (145 psi)
• 160 ... 5000 mbar (2.32 ... 72.5 psi)	30 bar (435 psi)
• 1 ... 30 bar (14.5 ... 435 psi)	100 bar (1450 psi)
Lower measuring limit	
• Measuring cell with silicone oil filling	0 mark (0 psi) absolute
Upper measuring limit	100% of max. span (max. 160 bar (2320 psi) with oxygen measurement and inert liquid)

Output

Output signal	4 ... 20 mA
---------------	-------------

Measuring accuracy

Reference conditions	Increasing characteristic Start-of-scale value 0 bar Stainless steel seal diaphragm Silicone oil filling Room temperature (25 °C (77 °F)) r: Span ratio (r = max. span / set span)	
Error in measurement and fixed-point setting (including hysteresis and repeatability)		
• Linear characteristic		
- $r \leq 10$	$\leq (0.0029 \cdot r + 0.071)\%$	
- $10 < r \leq 30$	$\leq (0.0045 \cdot r + 0.071)\%$	
Influence of ambient temperature		
• With -10 ... +60 °C (14 ... 140 °F)	$\leq (0.1 \cdot r + 0.2)\%$	
• With -40 ... -10 °C and +60 °C ... +85 °C (-40 ... +14 and 140 ... 185 °F)	$\leq (0.1 \cdot r + 0.15)\% / 10 \text{ K}$ ($\leq (0.1 \cdot r + 0.15)\% / 18 \text{ °F}$)	

Rated conditions

Degree of protection (to EN 60529)	IP65
Process temperature	
• Measuring cell with silicone oil filling	-40 ... +100 °C (-40 ... +212 °F)
• Measuring cell with inert filling liquid	-20 ... +100 °C (-4 ... +212 °F)
• In conjunction with dust explosion protection	-20 ... +60 °C (-4 ... +140 °F)

Design

Weight (without options)	$\approx 1.5 \text{ kg}$ ($\approx 3.3 \text{ lb}$)
Wetted parts materials	
• Connection shank	Stainless steel, mat. No. 1.4404/316L or Hastelloy C4, mat. No. 2.4610
• Seal diaphragm	Stainless steel, mat. No. 1.4404/316L or Hastelloy C276, mat. No. 2.4819
Measuring cell filling	Silicone oil or inert filling liquid (max. 160 bar (2320 psi) with oxygen measurement)

Process connection	Connection shank G $\frac{1}{2}$ A to DIN EN 837-1, female thread $\frac{1}{2}$ -14 NPT or oval flange (PN 160 (MWP 2320)) with mounting thread M10 or $\frac{7}{16}$ -20 UNF to EN 61518
--------------------	---

Power supply U_H

Terminal voltage on pressure transmitter	10.5 ... 45 V DC 10.5 ... 30 V DC in intrinsically-safe mode
--	---

Certificates and approvals

Classification according to pressure equipment directive (DRGL 97/23/EC)	For gases of fluid group 1 and liquids of fluid group 1; complies with requirements of article 3, paragraph 3 (sound engineering practice)
Explosion protection	
• Intrinsic safety "i"	PTB 99 ATEX 2122
- Identification	Ex II 1/2 G EEx ia/ib IIB/IIC T6
- Permissible ambient temperature	-40 ... +85 °C (-40 ... +185 °F) temperature class T4; -40 ... +70 °C (-40 ... +158 °F) temperature class T5; -40 ... +60 °C (-40 ... +140 °F) temperature class T6
- Connection	To certified intrinsically-safe circuits with maximum values: $U_i = 30 \text{ V}$, $I_i = 100 \text{ mA}$, $P_i = 750 \text{ mW}$; $R_i = 300 \Omega$
- Effective internal inductance/capacitance	$L_i = 0.4 \text{ mH}$, $C_i = 6 \text{ nF}$
• Explosion-proof "d"	PTB 99 ATEX 1160
- Identification	Ex II 1/2 G EEx d IIC T4/T6
- Permissible ambient temperature	-40 ... +85 °C (-40 ... +185 °F) temperature class T4; -40 ... +60 °C (-40 ... +140 °F) temperature class T6
- Connection	To circuits with values: $U_H = 10.5 \text{ ... } 45 \text{ V DC}$
• Dust explosion protection for zone 20	PTB 01 ATEX 2055
- Identification	Ex II 1 D IP65 T 120 °C Ex II 1/2 D IP65 T 120 °C
- Permissible ambient temperature	-40 ... +85 °C (-40 ... +185 °F)
- Max. surface temperature	120 °C (248 °F)
- Connection	To certified intrinsically-safe circuits with maximum values: $U_i = 30 \text{ V}$, $I_i = 100 \text{ mA}$, $P_i = 750 \text{ mW}$, $R_i = 300 \Omega$
- Effective internal inductance/capacitance	$L_i = 0.4 \text{ mH}$, $C_i = 6 \text{ nF}$
• Dust explosion protection for zone 21/22	PTB 01 ATEX 2055
- Identification	Ex II 2 D IP65 T 120 °C
- Connection	To circuits with values: $U_H = 10.5 \text{ ... } 45 \text{ V DC}$; $P_{\text{max}} = 1.2 \text{ W}$
• Type of protection "n" (zone 2)	TÜV 01 ATEX 1696 X
- Identification	Ex II 3 G EEx nA L IIC T4/T5/T6
• Explosion protection to FM	Certificate of Compliance 3008490
- Identification (XP/DIP) or (IS); (NI)	CL I, DIV 1, GP ABCD T4...T6; CL II, DIV 1, GP EFG; CL III; CL I, ZN 0/1 AEx ia IIC T4...T6; CL I, DIV 2, GP ABCD T4...T6; CL II, DIV 2, GP FG; CL III

SITRANS P measuring instruments for pressure

Transmitters for pressure, absolute pressure, differential pressure, flow and level

DS III series for absolute pressure (from pressure series)

- Explosion protection to CSA Certificate of Compliance 1153651
- Identification (XP/DIP) or (IS) CL I, DIV 1, GP ABCD T4...T6; CL II, DIV 1, GP EFG; CL III; Ex ia IIC T4...T6; CL I, DIV 2, GP ABCD T4...T6; CL II, DIV 2, GP FG; CL III

Dimensional drawings

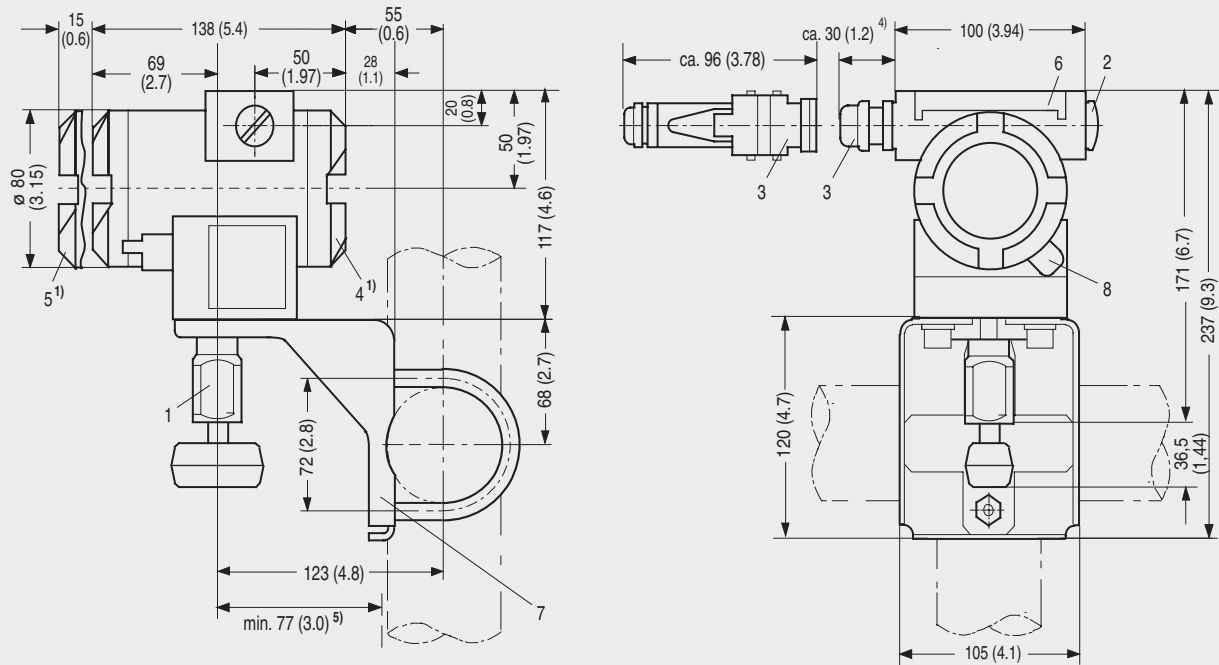

- Process connection:
 - 1/2-14 NPT,
 - connection shank G1/2A or
 - oval flange
- Blanking plug
- Electrical connection:
 - screwed gland Pg 13,5 (adapter)^{2) 3)},
 - screwed gland M20x1,5³⁾,
 - screwed gland 1/2-14 NPT or
 - Han 7D/ Han 8U plug^{2) 3)}
- Terminal side
- Electronics side, digital display (longer overall length for cover with window)
- Protective cover over keys
- Mounting bracket (option)
- Screw cover - safety bracket (only for type of protection "Explosion-proof enclosure", not shown in the drawing)

- 1) Allow approx. 20 mm (0.79 inch) thread length to permit unscrewing
- 2) Not with type of protection "explosion-proof enclosure"
- 3) Not with type of protection "FM + CSA [is + xp]"
- 4) 45 mm (1.8 inch) for Pg 13,5 with adapter
- 5) Minimum distance for rotation

SITRANS P pressure transmitters, DS III series for absolute pressure, from the pressure series, dimensional drawing, dimensions in mm (inch)

SITRANS P measuring instruments for pressure

Transmitters for pressure, absolute pressure, differential pressure, flow and level

DS III series for absolute pressure (from pressure series)

2

Selection and Ordering data		Order No.	
SITRANS P pressure transmitters, DS III series for absolute pressure from the pressure series		7 MF 4 2 3 3 -	
2-wire system		- - - - -	
Measuring cell filling	Measuring cell cleaning		
Silicone oil	Standard	1	
Inert liquid	Grease-free	3	
Measured span			
8.3 ... 250 mbar	(0.12 ... 3.63 psi)	E)	D
43 ... 1300 mbar	(0.62 ... 18.9 psi)	E)	F
0.16 ... 5 bar	(2.32 ... 72.5 psi)	E)	G
1 ... 30 bar	(14.5 ... 435 psi)		H
Wetted parts materials			
Seal diaphragm	Process connection		
Stainless steel	Stainless steel		A
Hastelloy	Stainless steel	E)	B
Hastelloy	Hastelloy	E)	C
Version for diaphragm seal ¹⁾			Y 0
Process connection			
• Connection shank G $\frac{1}{2}$ B to EN 837-1			0
• Female thread $\frac{1}{2}$ -14 NPT			1
• Oval flange made of stainless steel, max. span 160 bar (2320 psi)			
- Mounting thread $\frac{7}{16}$ -20 UNF to EN 61518			2
- Mounting thread M10 to DIN 19213			3
Non-wetted parts materials			
• Housing made of die-cast aluminium			0
• Housing stainless steel precision casting			3
Design			
• Standard design			1
• International version, English label inscriptions, documentation in 5 languages on CD			2
Explosion protection			
• without			A
• with ATEX, Type of protection:			
- "Intrinsic safety (EEx ia)"			B
- "Explosion-proof (EEx d)" ²⁾			D
- "Intrinsic safety and explosion-proof enclosure (EEx ia + EEx d)" ³⁾			P
- "n (zone 2)"			E
- "Intrinsic safety, explosion-proof enclosure and dust explosion protection (EEx ia + EEx d + zone 1D/2D)" ³⁾			R
• with FM + CSA, Type of protection:			
- "Intrinsic safety and explosion-proof (is + xp)" ²⁾			NC
Electrical connection / cable inlet			
• Screwed gland Pg 13.5 ⁴⁾			A
• Screwed gland M20x1.5			B
• Screwed gland $\frac{1}{2}$ -14 NPT			C
• Han 7D plug (plastic housing) incl. mating connector ⁴⁾			D
Display			
• without (digital indicator hidden, setting: mA)			1
• with visible digital indicator			6
• with customer-specific digital indicator (setting as specified, Order code "Y21" required)			7

4) Not together with type of protection "Explosion-proof"
E) Combinations of the versions marked with E) are subject to the export regulations AL: 2B230, ECCN: N.

Power supply units see "SITRANS I power supply units and input isolators".

The device is delivered together with brief instructions (Leporello) and a CD-ROM containing detailed documentation.

1) Version 7MF4233-1DY... only up to max. span 200 mbar (2.9 psi)

2) Without cable gland, with blanking plug

3) With enclosed cable gland EEx ia and blanking plug

SITRANS P measuring instruments for pressure

Transmitters for pressure, absolute pressure, differential pressure, flow and level

DS III series for absolute pressure (from pressure series)

2

Further designs	Order code	Further designs	Order code
Please add "-Z" to Order No. and specify Order code.		Please add "-Z" to Order No. and specify Order code.	
Pressure transmitter with mounting bracket made of:		Additional data	
• Steel	A01	Measuring range to be set	Y01
• Stainless steel	A02	specify in plain text: Y01: ... to ... mbar, bar, kPa, MPa, psi	
Plug		Measuring point number/identification	Y15
• Han 7D (metal, gray)	A30	max. 16 characters, specify in plain text: Y15:	
• Han 8U (instead of Han 7D)	A31	Measuring point text	Y16
Rating plate inscription (instead of German)		max. 27 characters, specify in plain text: Y16:	
• English	B11	Entry of HART address (TAG)	Y17
• French	B12	max. 8 characters, specify in plain text: Y17:	
• Spanish	B13	Setting of pressure indicator in pressure units	Y21
• Italian	B14	specify in plain text (standard setting: mA): Y21: mbar, bar, kPa, MPa, psi, ...	
English rating plate	B21	Note: The following pressure units can be selected: bar, mbar, mm H ₂ O [*] , inH ₂ O [*] , ftH ₂ O [*] , mmHG, inHG, psi, Pa, kPa, MPa, g/cm ² , kg/cm ² , mA, Torr, ATM or % *) Reference temperature 20 °C	
Pressure units in inH ₂ O or psi		Setting of pressure indicator in non-pressure units	Y22 + Y01
Manufacturer's test certificate M (calibration certificate)	C11	specify in plain text: Y22: up to l/min, m ³ /h, m, USgpm, ... (specification of measuring range in pressure units "Y01" is essential, unit with max. 5 characters)	
to DIN 55350, Part 18 and to ISO 8402			
Acceptance test certificate B	C12		
to EN 10204-3.1.B			
Factory certificate	C14		
to EN 10204-2.2			
Certificate "Functional Safety (SIL)"	C20		
Setting of upper limit of output signal to 22.0 mA	D05		
Acid gas version to NACE	D07		
(only together with seal diaphragm made of Hastelloy)			
Type of protection IP68	D12		
(not together with Han 7D / Han 8U plug, Pg 13.5 screwed gland)			
Digital indicator along side the input keys	D27		
(only together with the devices 7MF4233-....0-.A.6 or -.A.7-Z, Y21 or Y22 + Y01).			
Use in or at zone 1D/2D	E01		
(only together with type of protection "Intrinsic safety (EEx ia)*)			
Use at zone 0	E02		
(only together with type of protection "Intrinsic safety (EEx ia)*)			
Oxygen application	E10		
(max. 160 bar (2320 psi) with oxygen measurement and inert liquid)			
		Only the settings for "Y01", "Y21", "Y22" and "D05" can be made in the factory	

SITRANS P measuring instruments for pressure

Transmitters for pressure, absolute pressure, differential pressure, flow and level

DS III series for absolute pressure (from differential pressure series)

2

Technical specifications

SITRANS P pressure transmitters, DS III series for absolute pressure, from the differential pressure series

Input

Measured variable	Absolute pressure
Span	Maximum working pressure
• 8.3 ... 250 mbar (0.12 ... 3.6 psi)	32 bar (464 psi)
• 43 ... 1300 mbar (0.62 ... 18.9 psi)	32 bar (464 psi)
• 160 ... 5000 mbar (2.32 ... 72.5 psi)	32 bar (464 psi)
• 1 ... 30 bar (14.5 ... 435 psi)	160 bar (2320 psi)
• 5.3 ... 100 bar (76.9 ... 1450 psi)	160 bar (2320 psi)
	With connection thread M10 and $\frac{7}{16}$ -20 UNF in the process flanges
Lower measuring limit	
• Measuring cell with silicone oil filling	0 mark (0 psi) absolute
Upper measuring limit	100% of max. span (max. 160 bar (2320 psi) with oxygen measurement and inert liquid)
Start of scale	Continuously adjustable between the measuring limits

Output

Output signal	4 ... 20 mA
---------------	-------------

Measuring accuracy

Reference conditions	Increasing characteristic Start-of-scale value 0 bar Stainless steel seal diaphragm Silicone oil filling Room temperature (25 °C (77 °F)) r: Span ratio (r = max. span / set span)
Error in measurement and fixed-point setting (including hysteresis and repeatability)	
Linear characteristic	
- r ≤ 10	≤ (0.0029 · r + 0.071)%
- 10 < r ≤ 30	≤ (0.0045 · r + 0.071)%
Influence of ambient temperature	
• With -10 ... +60 °C (14 ... 140 °F)	≤ (0.1 · r + 0.2)% Twice the value with 20-mbar (0.29 psi) measuring cell
• With -40 ... -10 °C and +60 °C ... +85 °C (-40 ... +14 and 140 ... 185 °F)	≤ (0.1 · r + 0.15)% / 10 K (≤ (0.1 · r + 0.15)% / 18 °F) Twice the value with 20-mbar (0.29 psi) measuring cell

Rated conditions

Degree of protection (to EN 60529)	IP65
Process temperature	
• Measuring cell with silicone oil filling	-40 ... +100 °C (-40 ... +212 °F)
• Measuring cell with inert filling liquid	-20 ... +100 °C (-4 ... +212 °F)
• In conjunction with dust explosion protection	-20 ... +60 °C (-4 ... +140 °F)

Design

Weight (without options)	≈ 4.5 kg (≈ 9.9 lb)
Wetted parts materials	
• Seal diaphragm	Stainless steel, mat. No. 1.4404/316L, Hastelloy C276, mat. No. 2.4819, Monel, mat. No. 2.4360, tantalum or gold

Measuring cell filling	Silicone oil or inert filling liquid (max. 160 bar (2320 psi) with oxygen measurement)
Process connection	Female thread $\frac{1}{4}$ -18 NPT and flange connection to DIN 19 213 with mounting thread M10 or $\frac{7}{16}$ -20 UNF

Power supply U_H

Terminal voltage on pressure transmitter	10.5 ... 45 V DC 10.5 ... 30 V DC in intrinsically-safe mode
--	---

Certificates and approvals

Classification according to pressure equipment directive (DRGL 97/23/EC)	For gases of fluid group 1 and liquids of fluid group 1; complies with requirements of article 3, paragraph 3 (sound engineering practice)
Explosion protection	
• Intrinsic safety "i"	PTB 99 ATEX 2122
- Identification	Ex II 1/2 G EEx ia/ib IIB/IIC T6
- Permissible ambient temperature	-40 ... +85 °C (-40 ... +185 °F) temperature class T4; -40 ... +70 °C (-40 ... +158 °F) temperature class T5; -40 ... +60 °C (-40 ... +140 °F) temperature class T6
- Connection	To certified intrinsically-safe circuits with maximum values: $U_i = 30$ V, $I_i = 100$ mA, $P_i = 750$ mW; $R_i = 300$ Ω
- Effective internal inductance/capacitance	$L_i = 0.4$ mH, $C_i = 6$ nF
• Explosion-proof "d"	PTB 99 ATEX 1160
- Identification	Ex II 1/2 G EEx d IIC T4/T6
- Permissible ambient temperature	-40 ... +85 °C (-40 ... +185 °F) temperature class T4; -40 ... +60 °C (-40 ... +140 °F) temperature class T6
- Connection	To circuits with values: $U_H = 10.5$... 45 V DC
• Dust explosion protection for zone 20	PTB 01 ATEX 2055
- Identification	Ex II 1 D IP65 T 120 °C Ex II 1/2 D IP65 T 120 °C
- Permissible ambient temperature	-40 ... +85 °C (-40 ... +185 °F)
- Max. surface temperature	120 °C (248 °F)
- Connection	To certified intrinsically-safe circuits with maximum values: $U_i = 30$ V, $I_i = 100$ mA, $P_i = 750$ mW, $R_i = 300$ Ω
- Effective internal inductance/capacitance	$L_i = 0.4$ mH, $C_i = 6$ nF
• Dust explosion protection for zone 21/22	PTB 01 ATEX 2055
- Identification	Ex II 2 D IP65 T 120 °C
- Connection	To circuits with values: $U_H = 10.5$... 45 V DC; $P_{max} = 1.2$ W
• Type of protection "n" (zone 2)	TÜV 01 ATEX 1696 X
- Identification	Ex II 3 G EEx nA L IIC T4/T5/T6
• Explosion protection to FM	Certificate of Compliance 3008490
- Identification (XP/DIP) or (IS); (NI)	CL I, DIV 1, GP ABCD T4...T6; CL II, DIV 1, GP EFG; CL III; CL I, ZN 0/1 AEx ia IIC T4...T6; CL I, DIV 2, GP ABCD T4...T6; CL II, DIV 2, GP FG; CL III

SITRANS P measuring instruments for pressure

Transmitters for pressure, absolute pressure, differential pressure, flow and level

DS III series for absolute pressure (from differential pressure series)

- Explosion protection to CSA Certificate of Compliance 1153651
- Identification (XP/DIP) or (IS) CL I, DIV 1, GP ABCD T4...T6;
CL II, DIV 1, GP EFG; CL III; Ex ia
IIC T4...T6; CL I, DIV 2, GP ABCD
T4...T6; CL II, DIV 2, GP FG; CL III

Dimensional drawings

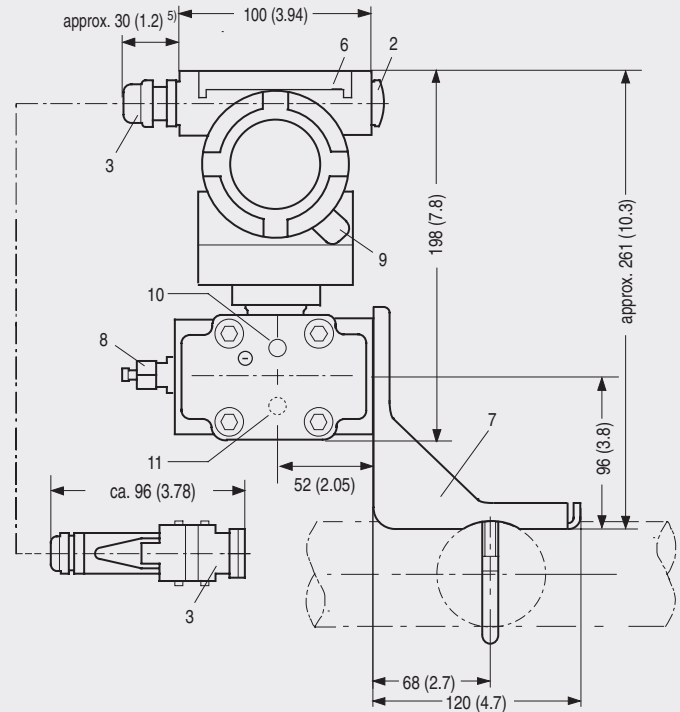
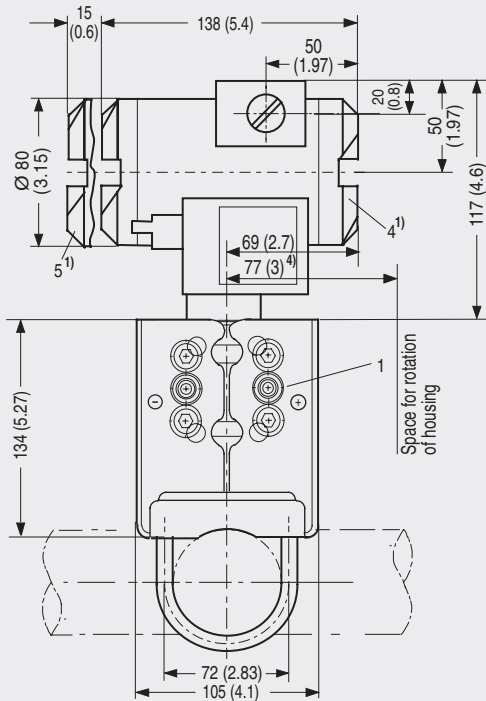

- Process connection: 1/4-18 NPT (EN 61518)
- Blanking plug
- Electrical connection:
 - screwed gland Pg 13,5 (adapter) ²⁾³⁾,
 - screwed gland M20x1,5 ³⁾,
 - screwed gland 1/2-14 NPT or
 - Han 7D/ Han 8U plug ²⁾³⁾
- Terminal side
- Electronics side, digital display (longer overall length for cover with window)
- Protective cover over keys
- Mounting bracket (option)
- Sealing screw with valve (option)
- Screw cover - safety bracket (only for type of protection "Explosion-proof enclosure", not shown in the drawing)
- Lateral venting for liquid measurement
- Lateral venting for gas measurement (suffix H02)

- Allow approx. 20 mm (0.79 inch) thread length to permit unscrewing
- Not with type of protection "explosion-proof enclosure"
- Not with type of protection "FM + CSA [is + xp]"
- 92 mm (3.62 inch) for minimum distance to permit rotation with indicator
- 45 mm (1.8 inch) for Pg 13,5 with adapter

SITRANS P pressure transmitters, DS III series for absolute pressure, from the differential pressure series, dimensional drawing, dimensions in mm (inch)

SITRANS P measuring instruments for pressure

Transmitters for pressure, absolute pressure, differential pressure, flow and level

**DS III series for absolute pressure
(from differential pressure series)**

2

Selection and Ordering data		Order No.	
SITRANS P pressure transmitters, DS III series for absolute pressure from the series Differential pressure		7 MF 4 3 3 3 -	
2-wire system		- - - - -	
Measuring cell filling	Measuring cell cleaning		
Silicone oil	Standard	1	
Inert liquid ¹⁾	Grease-free	3	
Measured span			
8.3 ... 250 mbar	(0.12 ... 3.63 psi)	E)	D
43 ... 1300 mbar	(0.62 ... 18.9 psi)	E)	F
0.16 ... 5 bar	(2.32 ... 72.5 psi)	E)	G
1 ... 30 bar	(14.5 ... 435 psi)		H
5.3 ... 100 bar	(76.9 ... 1450 psi)		KE
Wetted parts materials			
Seal diaphragm	Parts of measuring cell		
Stainless steel	Stainless steel		A
Hastelloy	Stainless steel	E)	B
Hastelloy	Hastelloy	E)	C
Tantalum	Tantalum		E
Monel	Monel	E)	H
Gold	Gold		L
Version for diaphragm seal ²⁾			Y
Process connection			
Female thread 1/4-18 NPT with flange connection			
• Sealing screw opposite process connection			
- Mounting thread M10 to DIN 19213			0
- Mounting thread 7/16-20 UNF to EN 61518			2
• Vent on side of process flange ³⁾			
- Mounting thread M10 to DIN 19213			4
- Mounting thread 7/16-20 UNF to EN 61518			6
Non-wetted parts materials			
Process flange screws	Electronics housing		
Stainless steel	Die-cast aluminium		2
Stainless steel	Stainless steel precision casting		3
Design			
• Standard design			1
• International version, English label inscriptions, documentation in 5 languages on CD			2
Explosion protection			
• without			A
• with ATEX, Type of protection:			
- "Intrinsic safety (EEx ia)"			B
- "Explosion-proof (EEx d)" ⁴⁾			D
- "Intrinsic safety and explosion-proof enclosure (EEx ia + EEx d)" ⁵⁾			P
- "n (zone 2)"			E
- "Intrinsic safety, explosion-proof enclosure and dust explosion protection (EEx ia + EEx d + zone 1D/2D)" ⁵⁾			R
• with FM + CSA, Type of protection:			
- "Intrinsic safety and explosion-proof (is + xp)" ⁴⁾			NC
Electrical connection / cable inlet			
• Screwed gland Pg 13.5 ⁶⁾			A
• Screwed gland M20x1.5			B
• Screwed gland 1/2-14 NPT			C
• Han 7D plug (plastic housing) incl. mating connector ⁶⁾			D

Selection and Ordering data		Order No.	
SITRANS P pressure transmitters, DS III series for absolute pressure from the series Differential pressure		7 MF 4 3 3 3 -	
2-wire system		- - - - -	
Display			
• without (digital indicator hidden, setting: mA)			1
• with visible digital indicator			6
• with customer-specific digital indicator (setting as specified, Order code "Y21" required)			7

Power supply units see "SITRANS I power supply units and input isolators".

Included in delivery of the device:

- Brief instructions (Leporello)
- CD-ROM with detailed documentation
- Sealing plug(s) or sealing screw(s) for the process flanges(s)

1) For oxygen applications, add Order code E10.

2) Version 7MF4433-1DY... only up to max. span 200 mbar (2.9 psi)

3) Not for span "5.3 ... 100 bar (76.9 ... 1450 psi)"

4) Without cable gland, with blanking plug

5) With enclosed cable gland EEx ia and blanking plug

6) Not together with type of protection "Explosion-proof"

E) Combinations of the versions marked with E) are subject to the export regulations AL: 2B230, ECCN: N.

SITRANS P measuring instruments for pressure

Transmitters for pressure, absolute pressure, differential pressure, flow and level

DS III series for absolute pressure (from differential pressure series)

2

Further designs	Order code
Please add "-Z" to Order No. and specify Order code.	
Pressure transmitter with mounting bracket made of:	
• Steel	A01
• Stainless steel	A02
O-rings for process flanges (instead of FPM (Viton))	
• PTFE (Teflon)	A20
• FEP (with silicone core, approved for food)	A21
• FFPM (Kalrez, compound 4079)	A22
• NBR (Buna N)	A23
Plug	
• Han 7D (metal, gray)	A30
• Han 8U (instead of Han 7D)	A31
Sealing screws	A40
¼-18 NPT, with valve in material of process flanges	
Rating plate inscription (instead of German)	
• English	B11
• French	B12
• Spanish	B13
• Italian	B14
English rating plate	B21
Pressure units in inH ₂ O or psi	
Manufacturer's test certificate M (calibration certificate)	C11
to DIN 55350, Part 18 and to ISO 8402	
Acceptance test certificate B	C12
to EN 10204-3.1.B	
Factory certificate	C14
to EN 10204-2.2	
Certificate "Functional Safety (SIL)"	C20
Setting of upper limit of output signal to 22.0 mA	D05
Acid gas version to NACE	D07
(only together with seal diaphragm made of Hastelloy)	
Type of protection IP68	D12
(not together with Han 7D / Han 8U plug, Pg 13.5 screwed gland)	
Digital indicator along side the input keys	D27
(only together with the devices 7MF4333-...0-.A6 or -.A.7-Z, Y21 or Y22 + Y01)	
Use in or at zone 1D/2D	E01
(only together with type of protection "Intrinsic safety (EEx ia)ᵀ")	
Use at zone 0	E02
(only together with type of protection "Intrinsic safety (EEx ia)ᵀ")	
Oxygen application	E10
(max. 160 bar (2320 psi) with oxygen measurement and inert liquid)	
Interchanging of process connection side	H01
Vent on side for gas measurements	H02
Process flange	
• Hastelloy	K01
• Monel	K02
• Stainless steel with PVDF insert max. PN 10 (MWP 145 psi), Max. temperature of medium 90 °C (194 °F)	K04

Further designs	Order code
Please add "-Z" to Order No. and specify Order code.	
Additional data	
Measuring range to be set	Y01
specify in plain text: Y01: ... up to ... mbar, bar, kPa, MPa, psi	
Measuring point number/identification	Y15
max. 16 characters, specify in plain text: Y15:	
Measuring point text	Y16
max. 27 characters, specify in plain text: Y16:	
Entry of HART address (TAG)	Y17
max. 27 characters, specify in plain text: Y17:	
Setting of pressure indicator in pressure units	Y21
specify in plain text (standard setting: mA): Y21: mbar, bar, kPa, MPa, psi, ...	
Note: The following pressure units can be selected: bar, mbar, mm H ₂ O [*] , inH ₂ O [*] , ftH ₂ O [*] , mmHG, inHG, psi, Pa, kPa, MPa, g/cm ² , kg/cm ² , mA, Torr, ATM or % *) Reference temperature 20 °C	
Setting of pressure indicator in non-pressure units	Y22 + Y01
specify in plain text: Y22: up to l/min, m ³ /h, m, USgpm, ... (specification of measuring range in pressure units "Y01" is essential, unit with max. 5 characters)	
Only the settings for "Y01", "Y21", "Y22" and "D05" can be made in the factory	

SITRANS P measuring instruments for pressure

Transmitters for pressure, absolute pressure, differential pressure, flow and level

DS III series for differential pressure and flow

2

Technical specifications

SITRANS P pressure transmitters, DS III series, for differential pressure and flow

Input

Measured variable	Differential pressure and flow
Span	Maximum working pressure
<ul style="list-style-type: none"> • PN 32 (MWP 464 psi) <ul style="list-style-type: none"> - 1 ... 20 mbar (0.0145 ... 0.29 psi) 32 bar (464 psi) • PN 160 (MWP 2320 psi) <ul style="list-style-type: none"> - 1 ... 60 mbar (0.0145 ... 0.87 psi) 160 bar (2320 psi) - 2.5 ... 250 mbar (0.036 ... 3.63 psi) 160 bar (2320 psi) - 6 ... 600 mbar (0.087 ... 8.7 psi) 160 bar (2320 psi) - 16 ... 1600 mbar (0.232 ... 23.2 psi) 160 bar (2320 psi) - 50 ... 5000 mbar (0.725 ... 72.5 psi) 160 bar (2320 psi) - 0.3 ... 30 bar (4.35 ... 435 psi) 160 bar (2320 psi) • PN 420 (MWP 6092) <ul style="list-style-type: none"> - 2.5 ... 250 mbar (0.036 ... 3.63 psi) 420 bar (6092 psi) - 6 ... 600 mbar (0.087 ... 8.7 psi) 420 bar (6092 psi) - 16 ... 1600 mbar (0.232 ... 23.3 psi) 420 bar (6092 psi) - 50 ... 5000 mbar (0.725 ... 72.5 psi) 420 bar (6092 psi) - 0.3 ... 30 bar (4.35 ... 435 psi) 420 bar (6092 psi) 	
Lower measuring limit	
<ul style="list-style-type: none"> • Measuring cell with silicone oil filling 	-100% of max. span (-33% with 30 bar (435 psi) measuring cell) or 30 mbar (0.44 psi) absolute
Upper measuring limit	100% of max. span (max. 160 bar (2320 psi) with oxygen measurement and inert liquid)

Output

Output signal	4 ... 20 mA
---------------	-------------

Measuring accuracy

Reference conditions	Increasing characteristic Start-of-scale value 0 bar Stainless steel seal diaphragm Silicone oil filling Room temperature (25 °C (77 °F)) r: Span ratio (r = max. span / set span)
Error in measurement and fixed-point setting (including hysteresis and repeatability)	
<ul style="list-style-type: none"> • Linear characteristic <ul style="list-style-type: none"> - $r \leq 10$ $\leq (0.0029 \cdot r + 0.071)\%$ - $10 < r \leq 30$ $\leq (0.0045 \cdot r + 0.071)\%$ - $30 < r \leq 100$ $\leq (0.005 \cdot r + 0.05)\%$ • Square-root characteristic (flow > 50%) <ul style="list-style-type: none"> - $r \leq 10$ $\leq 0.1\%$ - $10 < r \leq 30$ $\leq 0.2\%$ • Square-root characteristic (flow 25 ... 50%) <ul style="list-style-type: none"> - $r \leq 10$ $\leq 0.2\%$ - $10 < r \leq 30$ $\leq 0.4\%$ 	

Influence of ambient temperature	
<ul style="list-style-type: none"> • With -10 ... +60 °C (14 ... 140 °F) $\leq (0.08 \cdot r + 0.1)\%$ • With -40 ... -10 °C and +60 °C ... +85 °C (-40 ... +14 and 140 ... 185 °F) $\leq (0.1 \cdot r + 0.15)\% / 10 \text{ K}$ ($\leq (0.1 \cdot r + 0.15)\% / 18 \text{ °F}$) Twice the value with 20-mbar (0.29 psi) measuring cell. 	

Rated conditions

Degree of protection (to EN 60529)	IP65
Process temperature	
<ul style="list-style-type: none"> • Measuring cell with silicone oil filling 	-40 ... +100 °C (-40 ... +212 °F)
<ul style="list-style-type: none"> • Measuring cell with inert filling liquid 	-20 ... +100 °C (-4 ... +212 °F)
<ul style="list-style-type: none"> • In conjunction with dust explosion protection 	-20 ... +60 °C (-4 ... +140 °F)

Design

Weight (without options)	$\approx 4.5 \text{ kg}$ ($\approx 9.9 \text{ lb}$)
Wetted parts materials	
<ul style="list-style-type: none"> • Seal diaphragm 	Stainless steel, mat. No. 1.4404/316L, Hastelloy C276, mat. No. 2.4819, Monel, mat. No. 2.4360, tantalum or gold
Measuring cell filling	Silicone oil or inert filling liquid (max. 160 bar (2320 psi) with oxygen measurement)
Process connection	Female thread 1/4-18 NPT and flange connection to DIN 19 213 with mounting thread M10 or 7/16-20 UNF to EN 61518

Power supply U_H

Terminal voltage on pressure transmitter	10.5 ... 45 V DC 10.5 ... 30 V DC in intrinsically-safe mode
--	---

Certificates and approvals

Classification according to pressure equipment directive (DRGL 97/23/EC)	
<ul style="list-style-type: none"> • PN 32/160 (MWP 464/2320) 	For gases of fluid group 1 and liquids of fluid group 1; complies with requirements of article 3, paragraph 3 (sound engineering practice)
<ul style="list-style-type: none"> • PN 420 (MWP 6092) 	For gases of fluid group 1 and liquids of fluid group 1; complies with basic safety requirements of article 3, paragraph 1 (appendix 1); assigned to category III, conformity evaluation module H by the TÜV Nord

Explosion protection	
<ul style="list-style-type: none"> • Intrinsic safety "i" 	PTB 99 ATEX 2122
- Identification	Ex II 1/2 G EEx ia/ib IIB/IIC T6
- Permissible ambient temperature	-40 ... +85 °C (-40 ... +185 °F) temperature class T4; -40 ... +70 °C (-40 ... +158 °F) temperature class T5; -40 ... +60 °C (-40 ... +140 °F) temperature class T6
- Connection	To certified intrinsically-safe circuits with maximum values: $U_i = 30 \text{ V}$, $I_i = 100 \text{ mA}$, $P_i = 750 \text{ mW}$; $R_i = 300 \Omega$
- Effective internal inductance/capacitance	$L_i = 0.4 \text{ mH}$, $C_i = 6 \text{ nF}$

SITRANS P measuring instruments for pressure

Transmitters for pressure, absolute pressure, differential pressure, flow and level

DS III series for differential pressure and flow

• Explosion-proof "d"	PTB 99 ATEX 1160
- Identification	Ex II 1/2 G EEx d IIC T4/T6
- Permissible ambient temperature	-40 ... +85 °C (-40 ... +185 °F) temperature class T4; -40 ... +60 °C (-40 ... +140 °F) temperature class T6
- Connection	To circuits with values: $U_H = 10.5 \dots 45 \text{ V DC}$
• Dust explosion protection for zone 20	PTB 01 ATEX 2055
- Identification	Ex II 1 D IP65 T 120 °C Ex II 1/2 D IP65 T 120 °C
- Permissible ambient temperature	-40 ... +85 °C (-40 ... +185 °F)
- Max.surface temperature	120 °C (248 °F)
- Connection	To certified intrinsically-safe circuits with maximum values: $U_i = 30 \text{ V}$, $I_i = 100 \text{ mA}$, $P_i = 750 \text{ mW}$, $R_i = 300 \Omega$
- Effective internal inductance/capacitance	$L_i = 0.4 \text{ mH}$, $C_i = 6 \text{ nF}$
• Dust explosion protection for zone 21/22	PTB 01 ATEX 2055
- Identification	Ex II 2 D IP65 T 120 °C
- Connection	To circuits with values: $U_H = 10.5 \dots 45 \text{ V DC}$; $P_{\text{max}} = 1.2 \text{ W}$
• Type of protection "n" (zone 2)	TÜV 01 ATEX 1696 X
- Identification	Ex II 3 G EEx nA L IIC T4/T5/T6
• Explosion protection to FM	Certificate of Compliance 3008490
- Identification (XP/DIP) or (IS); (NI)	CL I, DIV 1, GP ABCD T4...T6; CL II, DIV 1, GP EFG; CL III; CL I, ZN 0/1 AEx ia IIC T4...T6; CL I, DIV 2, GP ABCD T4...T6; CL II, DIV 2, GP FG; CL III
• Explosion protection to CSA	Certificate of Compliance 1153651
- Identification (XP/DIP) or (IS)	CL I, DIV 1, GP ABCD T4...T6; CL II, DIV 1, GP EFG; CL III; Ex ia IIC T4...T6; CL I, DIV 2, GP ABCD T4...T6; CL II, DIV 2, GP FG; CL III

SITRANS P measuring instruments for pressure

Transmitters for pressure, absolute pressure, differential pressure, flow and level

DS III series for differential pressure and flow

2

Dimensional drawings

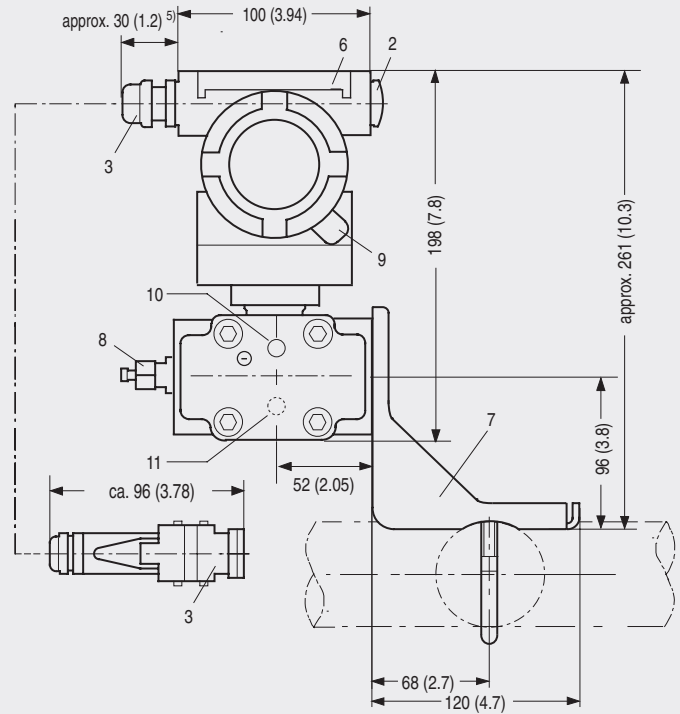
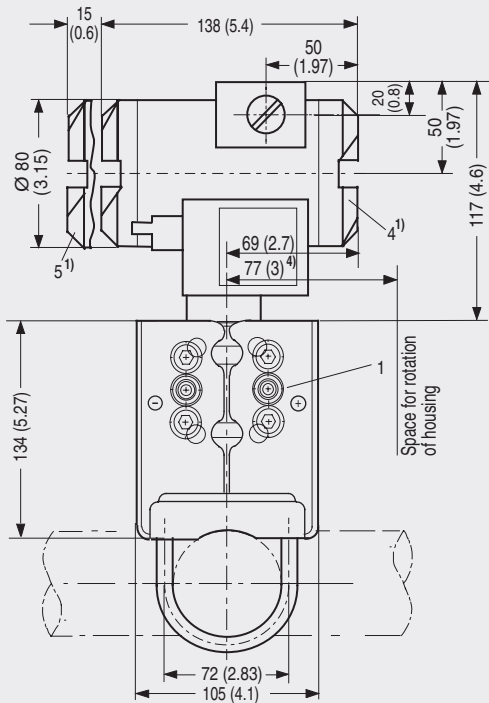

- 1 Process connection: 1/4-18 NPT (EN 61518)
- 2 Blanking plug
- 3 Electrical connection:
 - screwed gland Pg 13,5 (adapter)²⁾³⁾,
 - screwed gland M20x1,5³⁾,
 - screwed gland 1/2-14 NPT or
 - Han 7D/ Han 8U plug²⁾³⁾
- 4 Terminal side
- 5 Electronics side, digital display (longer overall length for cover with window)
- 6 Protective cover over keys
- 7 Mounting bracket (option)
- 8 Sealing screw with valve (option)
- 9 Screw cover - safety bracket (only for type of protection "Explosion-proof enclosure", not shown in the drawing)
- 10 Lateral venting for liquid measurement
- 11 Lateral venting for gas measurement (suffix H02)

- 1) Allow approx. 20 mm (0.79 inch) thread length to permit unscrewing
- 2) Not with type of protection "explosion-proof enclosure"
- 3) Not with type of protection "FM + CSA [is + xp]"
- 4) 92 mm (3.62 inch) for minimum distance to permit rotation with indicator
- 5) 45 mm (1.8 inch) for Pg 13,5 with adapter

SITRANS P pressure transmitters, DS III series for differential pressure and flow, dimensional drawing, dimensions in mm (inch)

SITRANS P measuring instruments for pressure

Transmitters for pressure, absolute pressure, differential pressure, flow and level

DS III series for differential pressure and flow

2

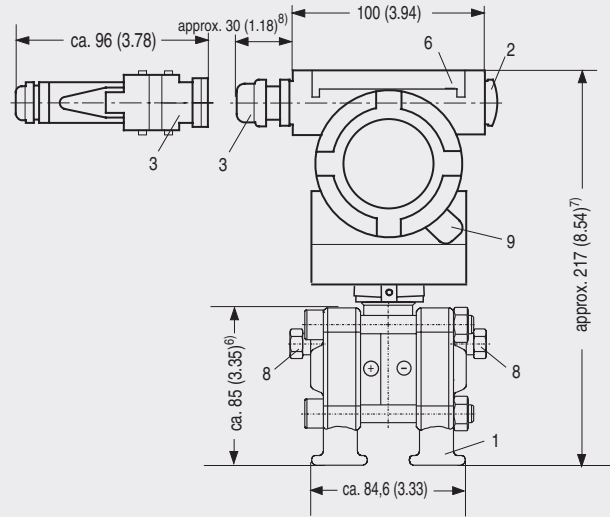
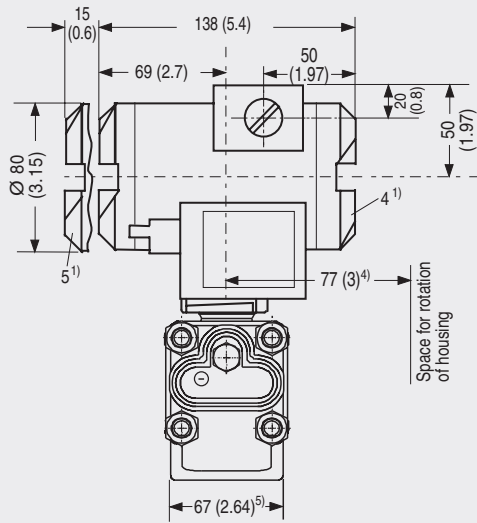

- 1 Process connection: 1/4-18 NPT (EN 61518)
- 2 Blanking plug
- 3 Electrical connection:
 - screwed gland Pg 13,5 (adapter)^{2) 3)},
 - screwed gland M20x1,5³⁾,
 - screwed gland 1/2-14 NPT or
 - Han 7D/ Han 8U plug^{2) 3)}
- 4 Terminal side
- 5 Electronics side, digital display (longer overall length for cover with window)
- 6 Protective cover over keys
- 7 Mounting bracket (option)
- 8 Sealing screw with valve (option)
- 9 Screw cover - safety bracket (only for type of protection "Explosion-proof enclosure", not shown in the drawing)

- 1) Allow approx. 20 mm (0.79 inch) thread length to permit unscrewing
- 2) Not with type of protection "explosion-proof enclosure"
- 3) Not with type of protection "FM + CSA [is + xp]"
- 4) 92 mm (3.6 inch) for minimum distance to permit rotation with indicator
- 5) 74 mm (2.9 inch) for PN \geq 420 (MWP \geq 6092 psi)
- 6) 91 mm (3.6 inch) for PN \geq 420 (MWP \geq 6092 psi)
- 7) 219 mm (8.62 inch) for PN \geq 420 (MWP \geq 6092 psi)
- 8) 45 mm (1.8 inch) for Pg 13,5 with adapter

SITRANS P pressure transmitters, DS III series for differential pressure and flow, with process covers for vertical differential pressure lines, dimensional drawing, dimensions in mm (inch)

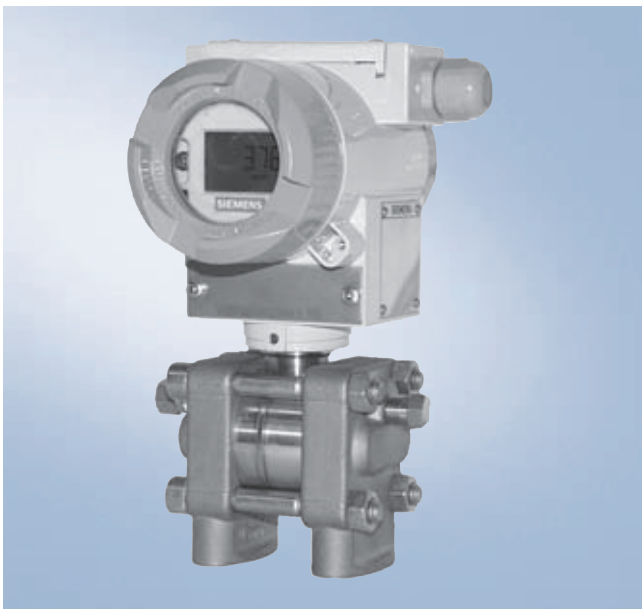

SITRANS P pressure transmitters, DS III series for differential pressure and flow, with process covers for vertical differential pressure lines

SITRANS P measuring instruments for pressure

Transmitters for pressure, absolute pressure, differential pressure, flow and level

DS III series for differential pressure and flow

2

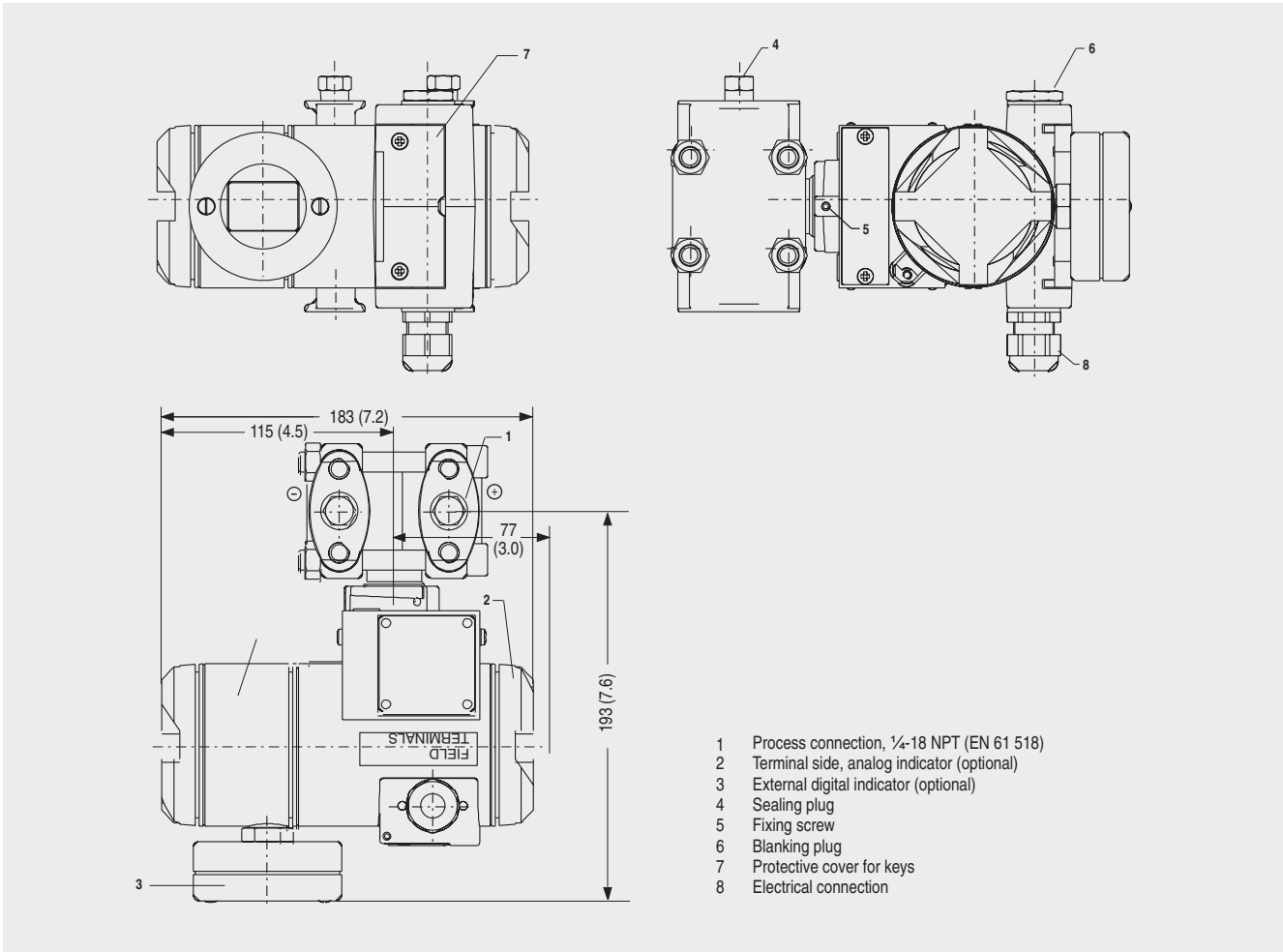

SITRANS P pressure transmitters, DS III series for differential pressure and flow, with digital indicator beside control keys, dimensional drawing, dimensions in mm (inch)

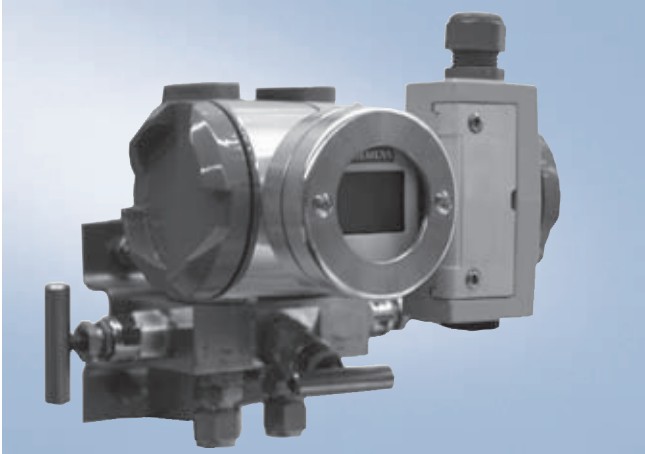

SITRANS P pressure transmitters, DS III series for differential pressure and flow, with digital indicator beside control keys

SITRANS P measuring instruments for pressure

Transmitters for pressure, absolute pressure, differential pressure, flow and level

DS III series for differential pressure and flow

2

Selection and Ordering data		Order No.
SITRANS P pressure transmitters, DS III series for differential pressure and flow PN 32/160 (MWP 464/2320 psi)		7 MF 4 4 3 3 -
2-wire system		
Measuring cell filling	Measuring cell cleaning	
Silicone oil	standard	▶ 1
Inert liquid ¹⁾	grease-free	▶ 3
Measured span		
PN 32 (MWP 464 psi)		
1 ... 20 mbar ²⁾	(0.0145 ... 0.29 psi)	▶ B
PN 160 (MWP 2320 psi)		
1 ... 60 mbar	(0.0145 ... 0.87 psi)	▶ C
2.5 ... 250 mbar	(0.036 ... 3.63 psi)	▶ D
6 ... 600 mbar	(0.087 ... 8.70 psi)	▶ E
16 ... 1600 mbar	(0.232 ... 23.2 psi)	▶ F
50 ... 5000 mbar	(0.725 ... 72.5 psi)	▶ G
0.3 ... 30 bar	(4.35 ... 435 psi)	▶ H
Wetted parts materials		
(stainless steel process flanges)		
Seal diaphragm	Parts of measuring cell	
Stainless steel	Stainless steel	▶ A
Hastelloy	Stainless steel	B
Hastelloy	Hastelloy	C
Tantalum ³⁾	Tantalum	E
Monel ³⁾	Monel	H
Gold ³⁾	Gold	L
Version for diaphragm seal		Y
Process connection		
Female thread 1/4-18 NPT with flange connection		
• Sealing screw opposite process connection		
- Mounting thread M10 to DIN 19213		▶ 0
- Mounting thread 7/16-20 UNF to EN 61518		2
• Vent on side of process flange ²⁾		
- Mounting thread M10 to DIN 19213		4
- Mounting thread 7/16-20 UNF to EN 61518		6
Non-wetted parts materials		
Process flange screws		
Stainless steel	Die-cast aluminium	▶ 2
Stainless steel	Stainless steel precision casting	3
Design		
• Standard design		1
• International version, English label inscriptions, documentation in 5 languages on CD		▶ 2
Explosion protection		
• without		A
• with ATEX, Type of protection:		
- "Intrinsic safety (EEx ia)"		B
- "Explosion-proof (EEx d)" ⁴⁾		D
- "Intrinsic safety and explosion-proof enclosure (EEx ia + EEx d)" ⁵⁾		▶ P
- "n (zone 2)"		E
- "Intrinsic safety, explosion-proof enclosure and dust explosion protection (EEx ia + EEx d + zone 1D/2D)" ⁵⁾		R
• with FM + CSA, Type of protection:		
- "Intrinsic safety and explosion-proof (is + xp)" ⁴⁾		NC
Electrical connection / cable inlet		
• Screwed gland Pg 13.5 ⁶⁾		A
• Screwed gland M20x1.5		▶ B
• Screwed gland 1/2-14 NPT		C
• Han 7D plug (plastic housing) incl. mating connector ⁶⁾		D

Selection and Ordering data		Order No.
SITRANS P pressure transmitters, DS III series for differential pressure and flow PN 32/160 (MWP 464/2320 psi)		7 MF 4 4 3 3 -
2-wire system		
Display		
• without (digital indicator hidden, setting: mA)		▶ 1
• with visible digital indicator		6
• with customer-specific digital indicator (setting as specified, Order code "Y21" required)		7
▶ Available ex stock		
Power supply units see "SITRANS I power supply units and input isolators".		
Included in delivery of the device:		
• Brief instructions (Leporello)		
• CD-ROM with detailed documentation		
• Sealing plug(s) or sealing screw(s) for the process flanges(s)		
1) For oxygen application, add Order code E10.		
2) Not suitable for connection of remote seal		
3) Only together with max. spans 250, 1600, 5000 and 30000 mbar (3.63, 23.2, 72.5 and 435 psi).		
4) Without cable gland, with blanking plug		
5) With enclosed cable gland EEx ia and blanking plug		
6) Not together with type of protection "Explosion-proof"		

SITRANS P measuring instruments for pressure

Transmitters for pressure, absolute pressure, differential pressure, flow and level

DS III series for differential pressure and flow

2

Further designs	Order code
Please add "-Z" to Order No. and specify Order code.	
Pressure transmitter with mounting bracket made of:	
• Steel	A01
• Stainless steel	A02
O-rings for process flanges (instead of FPM (Viton))	
• PTFE (Teflon)	A20
• FEP (with silicone core, approved for food)	A21
• FFPM (Kalrez, compound 4079)	A22
• NBR (Buna N)	A23
Plug	
• Han 7D (metal, gray)	A30
• Han 8U (instead of Han 7D)	A31
Sealing screws ¼-18 NPT, with valve in material of process flanges	A40
Rating plate inscription (instead of German)	
• English	B11
• French	B12
• Spanish	B13
• Italian	B14
English rating plate (calibration certificate) Pressure units in inH ₂ O or psi	B21
Manufacturer's test certificate M to DIN 55.350, Part 18 and to ISO 8402	C11
Acceptance test certificate B to EN 10 204-3.1.B	C12
Factory certificate to EN 10.204-2.2	C14
Certificate "Functional Safety (SIL)"	C20
Setting of upper limit of output signal to 22.0 mA	D05
Acid gas version to NACE (only together with seal diaphragm made of Hastelloy)	D07
Type of protection IP68 (not together with Han 7D / Han 8U plug, Pg 13.5 screwed gland)	D12
Digital indicator along side the input keys (only together with the devices 7MF4433-....0-.A.6 or -.A.7-Z, Y21 or Y22 + Y01)	D27
Use in or at zone 1D/2D (only together with type of protection "Intrinsic safety (EEx ia)")	E01
Use at zone 0 (only together with type of protection "Intrinsic safety (EEx ia)")	E02
TÜV approval to AD/TRD	E06
Overfilling safety device for flammable and non-flammable liquids (max. PN 32 (MVWP 464 psi), basic device with type of protection "Intrinsic safety (EEx ia)", to WHG and VbF)	E08

Further designs	Order code
Please add "-Z" to Order No. and specify Order code.	
Oxygen application (max. 160 bar (2320 psi) with oxygen measurement and inert liquid)	E10
Interchanging of process connection side	H01
Vent on side for gas measurements	H02
Stainless steel process flanges for vertical differential pressure lines (not together with K01, K02 and K04) ¹⁾	H03
Process flange	
• Hastelloy	K01
• Monel	K02
• Stainless steel with PVDF insert Max. PN 10 (MVWP 145 psi) Max. temperature of medium 90 °C (194 °F)	K04
Additional data	
Measuring range to be set specify in plain text:	
• with linear characteristic: Y01: ... up to ... mbar, bar, kPa, MPa, psi	Y01
• with square-root characteristic: Y02: ... up to ... mbar, bar, kPa, MPa, psi	Y02
Measuring point number/identification max. 16 characters, specify in plain text: Y15:	Y15
Measuring point text max. 27 characters, specify in plain text: Y16:	Y16
Entry of HART address (TAG) max. 27 characters, specify in plain text: Y17:	Y17
Setting of pressure indicator in pressure units specify in plain text (standard setting: mA): Y21: mbar, bar, kPa, MPa, psi, ... Note: The following pressure units can be selected: bar, mbar, mm H ₂ O [*] , inH ₂ O [*] , ftH ₂ O [*] , mmHG, inHG, psi, Pa, kPa, MPa, g/cm ² , kg/cm ² , mA, Torr, ATM or % *) Reference temperature 20 °C	Y21
Setting of pressure indicator in non-pressure units specify in plain text: Y22: up to l/min, m ³ /h, m, USgpm, ... (specification of measuring range in pressure units "Y01" or "Y02" is essential, unit with max. 5 characters)	Y22 ²⁾ Y01 or Y02
Only the settings for "Y01", "Y21", "Y21", "Y22" and "D05" can be made in the factory	
1) Not suitable for connection of remote seal	
2) Not together with over-filling safety device for flammable and non-flammable liquids (Order code "E08")	

SITRANS P measuring instruments for pressure

Transmitters for pressure, absolute pressure, differential pressure, flow and level

DS III series for differential pressure and flow

2

Selection and Ordering data		Order No.
SITRANS P pressure transmitters, DS III series for differential pressure and flow PN 420 (MWP 6092 psi) 2-wire system		7 MF 4 5 3 3 -
Measuring cell filling Silicone oil	Measuring cell cleaning Standard	1
Measured span		
2.5 ... 250 mbar	(0.036 ... 3.63 psi)	D
6 ... 600 mbar	(0.087 ... 8.70 psi)	E
16 ... 1600 mbar	(0.232 ... 23.2 psi)	F
50 ... 5000 mbar	(0.725 ... 72.5 psi)	G
0.3 ... 30 bar	(4.35 ... 435 psi)	H
Wetted parts materials (stainless steel process flanges)		
Seal diaphragm	Parts of measuring cell	
Stainless steel	Stainless steel	A
Hastelloy	Stainless steel	B
Gold ¹⁾	Gold	L
Process connection		
Female thread 1/4-18 NPT with flange connection		
• Sealing screw opposite process connection		
- Mounting thread M12 to DIN 19213		1
- Mounting thread 7/16-20 UNF to EN 61518		3
• Vent on side of process flanges		
- Mounting thread M12 to DIN 19213		5
- Mounting thread 7/16-20 UNF to EN 61518		7
Non-wetted parts materials		
Process flange screws	Electronics housing	
Stainless steel	Die-cast aluminium	2
Stainless steel	Stainless steel precision casting	3
Design		
• Standard design		1
• International version, English label inscriptions, documentation in 5 languages on CD		2
Explosion protection		
• without		A
• with ATEX, Type of protection:		
- "Intrinsic safety (EEx ia)"		B
- "Explosion-proof (EEx d)" ²⁾		D
- "Intrinsic safety and explosion-proof enclosure (EEx ia + EEx d)" ³⁾		P
- "n (zone 2)"		E
- "Intrinsic safety, explosion-proof enclosure and dust explosion protection (EEx ia + EEx d + zone 1D/2D)" ³⁾		R
• with FM + CSA, Type of protection:		
- "Intrinsic safety and explosion-proof (is + xp)" ²⁾ , max. PN 360		NC
Electrical connection / cable inlet		
• Screwed gland Pg 13.5 ⁴⁾		A
• Screwed gland M20x1.5		B
• Screwed gland 1/2-14 NPT		C
• Han 7D plug (plastic housing) incl. mating connector ⁴⁾		D

Selection and Ordering data		Order No.
SITRANS P pressure transmitters, DS III series for differential pressure and flow PN 420 (MWP 6092 psi) 2-wire system		7 MF 4 5 3 3 -
Display		
• without (digital indicator hidden, setting: mA)		1
• with visible digital indicator		6
• with customer-specific digital indicator (setting as specified, Order code "Y21" required)		7
Power supply units see "SITRANS I power supply units and input isolators".		
Scope of delivery: Pressure transmitter as ordered (Instruction Manual is extra ordering item)		
1) Not together with max. span 600 mbar		
2) Without cable gland, with blanking plug		
3) With enclosed cable gland EEx ia and blanking plug		
4) Not together with type of protection "Explosion-proof"		

SITRANS P measuring instruments for pressure

Transmitters for pressure, absolute pressure, differential pressure, flow and level

DS III series for differential pressure and flow

2

Further designs	Order code	Further designs	Order code
Please add "-Z" to Order No. and specify Order code.		Please add "-Z" to Order No. and specify Order code.	
Pressure transmitter with mounting bracket made of:		Additional data	
• Steel	A01	Measuring range to be set	
• Stainless steel	A02	specify in plain text:	
O-rings for process flanges		• with linear characteristic:	Y01
(instead of FPM (Viton))		Y01: ... up to ... mbar, bar, kPa, MPa, psi	
• PTFE (Teflon)	A20	• with square-root characteristic:	Y02
• FEP (with silicone core, approved for food)	A21	Y01: ... up to ... mbar, bar, kPa, MPa, psi	
• FFPM (Kalrez, compound 4079)	A22	Measuring point number/identification	Y15
• NBR (Buna N)	A23	max. 16 characters, specify in plain text:	
Plug		Y15:	
• Han 7D (metal, gray)	A30	Measuring point text	Y16
• Han 8U (instead of Han 7D)	A31	max. 27 characters, specify in plain text:	
Sealing screws	A40	Y16:	
1/4-18 NPT, with valve in material of process flanges		Entry of HART address (TAG)	Y17
Rating plate inscription		max. 27 characters, specify in plain text:	
(instead of German)		Y17:	
• English	B11	Setting of pressure indicator in pressure units	Y21
• French	B12	specify in plain text (standard setting: mA):	
• Spanish	B13	Y21: mbar, bar, kPa, MPa, psi, ...	
• Italian	B14	Note:	
English rating plate	B21	The following pressure units can be selected:	
Pressure units in inH ₂ O or psi		bar, mbar, mm H ₂ O [*] , inH ₂ O [*] , ftH ₂ O [*] , mmHG, inHG,	
Manufacturer's test certificate M	C11	psi, Pa, kPa, MPa, g/cm ² , kg/cm ² , mA, Torr, ATM or %	
(calibration certificate)		*) Reference temperature 20 °C	
to DIN 55350, Part 18 and to ISO 8402		Setting of pressure indicator in non-pressure units	Y22 + Y01 or Y02
Acceptance test certificate B	C12	specify in plain text:	
to EN 10204-3.1.B		Y22: up to l/min, m ³ /h, m, USgpm, ...	
Factory certificate	C14	(specification of measuring range in pressure units	
to EN 10204-2.2		"Y01" or "Y02" is essential, unit with max. 5 characters)	
Certificate "Functional Safety (SIL)"	C20	Only the settings for "Y01", "Y21", "Y22" and "D05" can be made in the	
Setting of upper limit of output signal to 22.0 mA	D05	factory	
Acid gas version to NACE	D07		
(only together with seal diaphragm made of Hastelloy)			
Type of protection IP68	D12		
(not together with Han 7D / Han 8U plug, Pg 13.5 screwed gland)			
Digital indicator along side the input keys	D27		
(only together with the devices 7MF4533-....2-.A.6 or -.A.7-Z, Y21 or Y22 + Y01)			
Use in or at zone 1D/2D	E01		
(only together with type of protection "Intrinsic safety (EEx ia)")			
Use at zone 0	E02		
(only together with type of protection "Intrinsic safety (EEx ia)")			
Interchanging of process connection side	H01		
Stainless steel process flanges for vertical differential pressure lines	H03		

SITRANS P measuring instruments for pressure

Transmitters for pressure, absolute pressure, differential pressure, flow and level

DS III series for level

Technical specifications

SITRANS P pressure transmitters, DS III series, for level

Input

Measured variable	Level
Span	Maximum working pressure (nominal pressure)
<ul style="list-style-type: none"> • 25 ... 250 mbar (0.36 ... 3.63 psi) • 25 ... 600 mbar (0.36 ... 8.7 psi) • 53 ... 1600 mbar (0.77 ... 23.2 psi) • 160 ... 5000 mbar (2.32 ... 72.5 psi) 	See "Mounting flange"
Lower measuring limit (measuring cell with silicone oil filling)	-100% of max. span or 30 mbar (0.435 psi) abs., depending on mounting flange
Upper measuring limit	100% of max. span

Output

Output signal	4 ... 20 mA
---------------	-------------

Measuring accuracy

Reference conditions	Increasing characteristic Start-of-scale value 0 bar Stainless steel seal diaphragm Mounting flange without tube Silicone oil filling Room temperature (25 °C (77 °F)) r: Span ratio (r = max. span / set span)
----------------------	--

Error in measurement and fixed-point setting (including hysteresis and repeatability)

• Linear characteristic	
- $r \leq 10$	$\leq 0.15\%$
- $10 < r \leq 30$	$\leq 0.3\%$
- $30 < r \leq 100$	$(0.0075 \cdot r + 0.075)\%$

Influence of ambient temperature

• With -10 ... +60 °C (14 ... 140 °F)	
- 250-mbar (3.63 psi) measuring cell	$\leq (0.5 \cdot r + 0.2)\%$ (0.4 instead of 0.2 with $10 < r \leq 30$)
- 600-mbar (8.7 psi) measuring cell	$\leq (0.3 \cdot r + 0.2)\%$ (0.4 instead of 0.2 with $10 < r \leq 30$)
- 1,600 and 5,000 mbar (23.2 and 72.5 psi) measuring cells	$\leq (0.25 \cdot r + 0.2)\%$ (0.4 instead of 0.2 with $10 < r \leq 30$)
• With -40 ... -10 °C and +60 °C ... +85 °C (-40 ... +14 and 140 ... 185 °F)	
- 250-mbar (3.63 psi) measuring cell	$\leq (0.25 \cdot r + 0.15)\% / 10 \text{ K}$ ($\leq (0.25 \cdot r + 0.15)\% / 18 \text{ °F}$) (Twice the value for $10 < r \leq 30$)
- 600-mbar (8.7 psi) measuring cell	$\leq (0.15 \cdot r + 0.15)\% / 10 \text{ K}$ ($\leq (0.15 \cdot r + 0.15)\% / 18 \text{ °F}$) (Twice the value for $10 < r \leq 30$)
- 1,600 and 5,000 mbar (23.2 and 72.5 psi) measuring cells	$\leq (0.12 \cdot r + 0.15)\% / 10 \text{ K}$ ($\leq (0.12 \cdot r + 0.15)\% / 18 \text{ °F}$) (Twice the value for $10 < r \leq 30$)

Rated conditions

Degree of protection (to EN 60529)	IP65
Process temperature	Note: Note the assignment of the max. permissible operating temperature to the max. permissible operating pressure of the respective flange connection!

Measuring cell with silicone oil filling

- High-pressure side	$p_{\text{abs}} \geq 1 \text{ bar: } -40 \dots +175 \text{ °C}$ (-40 ... +347 °F)
	$p_{\text{abs}} < 1 \text{ bar: } -40 \dots +80 \text{ °C}$ (-40 ... +176 °F)
- Low-pressure side	-40 ... +100 °C (-40 ... +212 °F) -20 ... +60 °C (-4 ... +140 °F) in conjunction with dust explosion protection

Design

Weight (without options)	
• To DIN (pressure transmitter with mounting flange, without tube)	$\approx 11 \dots 13 \text{ kg}$ ($\approx 24.2 \dots 28.7 \text{ lb}$)
• To ANSI (pressure transmitter with mounting flange, without tube)	$\approx 11 \dots 18 \text{ kg}$ ($\approx 24.2 \dots 39.7 \text{ lb}$)
Wetted parts materials	
• High-pressure side: Seal diaphragm of mounting flange	Stainless steel, mat. No. 1.4404/316L, Monel 400, mat. No. 2.4360, Hastelloy B2, mat. No. 2.4617, Hastelloy C276, mat. No. 2.4819, Hastelloy C4, mat. No. 2.4610, tantalum, PTFE, ECTFE
Measuring cell filling	Silicone oil
Process connection	
• High-pressure side	Flange to DIN and ANSI
• Low-pressure side	Female thread 1/4-18 NPT and flange connection to DIN 19213 with mounting thread M10 or 7/16-20 UNF to EN 61518

Power supply U_{H}

Terminal voltage on pressure transmitter	10.5 ... 45 V DC 10.5 ... 30 V DC in intrinsically-safe mode
--	---

Certificates and approvals

Classification according to pressure equipment directive (DRGL 97/23/EC)	For gases of fluid group 1 and liquids of fluid group 1; complies with requirements of article 3, paragraph 3 (sound engineering practice)
Explosion protection	
• Intrinsic safety "i"	PTB 99 ATEX 2122
- Identification	Ex II 1/2 G EEx ia/ib IIB/IIC T6
- Permissible ambient temperature	-40 ... +85 °C (-40 ... +185 °F) temperature class T4; -40 ... +70 °C (-40 ... +158 °F) temperature class T5; -40 ... +60 °C (-40 ... +140 °F) temperature class T6
- Connection	To certified intrinsically-safe circuits with maximum values: $U_{\text{i}} = 30 \text{ V}$, $I_{\text{i}} = 100 \text{ mA}$, $P_{\text{i}} = 750 \text{ mW}$; $R_{\text{i}} = 300 \Omega$
- Effective internal inductance/capacitance	$L_{\text{i}} = 0.4 \text{ mH}$, $C_{\text{i}} = 6 \text{ nF}$
• Explosion-proof "d"	PTB 99 ATEX 1160
- Identification	Ex II 1/2 G EEx d IIC T4/T6
- Permissible ambient temperature	-40 ... +85 °C (-40 ... +185 °F) temperature class T4; -40 ... +60 °C (-40 ... +140 °F) temperature class T6
- Connection	To circuits with values: $U_{\text{H}} = 10.5 \dots 45 \text{ V DC}$

SITRANS P measuring instruments for pressure

Transmitters for pressure, absolute pressure, differential pressure, flow and level

DS III series for level

2

• Dust explosion protection for zone 20	PTB 01 ATEX 2055
- Identification	Ex II 1 D IP65 T 120 °C Ex II 1/2 D IP65 T 120 °C
- Permissible ambient temperature	-40 ... +85 °C (-40 ... +185 °F)
- Max. surface temperature	120 °C (248 °F)
- Connection	To certified intrinsically-safe circuits with maximum values: $U_i = 30 \text{ V}$, $I_i = 100 \text{ mA}$, $P_i = 750 \text{ mW}$, $R_i = 300 \Omega$
- Effective internal inductance/capacitance	$L_i = 0.4 \text{ mH}$, $C_i = 6 \text{ nF}$
• Dust explosion protection for zone 21/22	PTB 01 ATEX 2055
- Identification	Ex II 2 D IP65 T 120 °C
- Connection	To circuits with values: $U_H = 10.5 \dots 45 \text{ V DC}$; $P_{\text{max}} = 1.2 \text{ W}$
• Type of protection "n" (zone 2)	TÜV 01 ATEX 1696 X
- Identification	Ex II 3 G EEx nA L IIC T4/T5/T6
• Explosion protection to FM	Certificate of Compliance 3008490
- Identification (XP/DIP) or (IS); (NI)	CL I, DIV 1, GP ABCD T4...T6; CL II, DIV 1, GP EFG; CL III; CL I, ZN 0/1 AEx ia IIC T4...T6; CL I, DIV 2, GP ABCD T4...T6; CL II, DIV 2, GP FG; CL III
• Explosion protection to CSA	Certificate of Compliance 1153651
- Identification (XP/DIP) or (IS)	CL I, DIV 1, GP ABCD T4...T6; CL II, DIV 1, GP EFG; CL III; Ex ia IIC T4...T6; CL I, DIV 2, GP ABCD T4...T6; CL II, DIV 2, GP FG; CL III

Mounting flange

Nom. diam.	Nom. press.
• To EN 1092-1	
- DN 80	PN 40
- DN 100	PN 16 PN 40
• To ASME B16.5	
- 3 inch	class 150 class 300
- 4 inch	class 150 class 300

SITRANS P measuring instruments for pressure

Transmitters for pressure, absolute pressure, differential pressure, flow and level

DS III series for level

Dimensional drawings

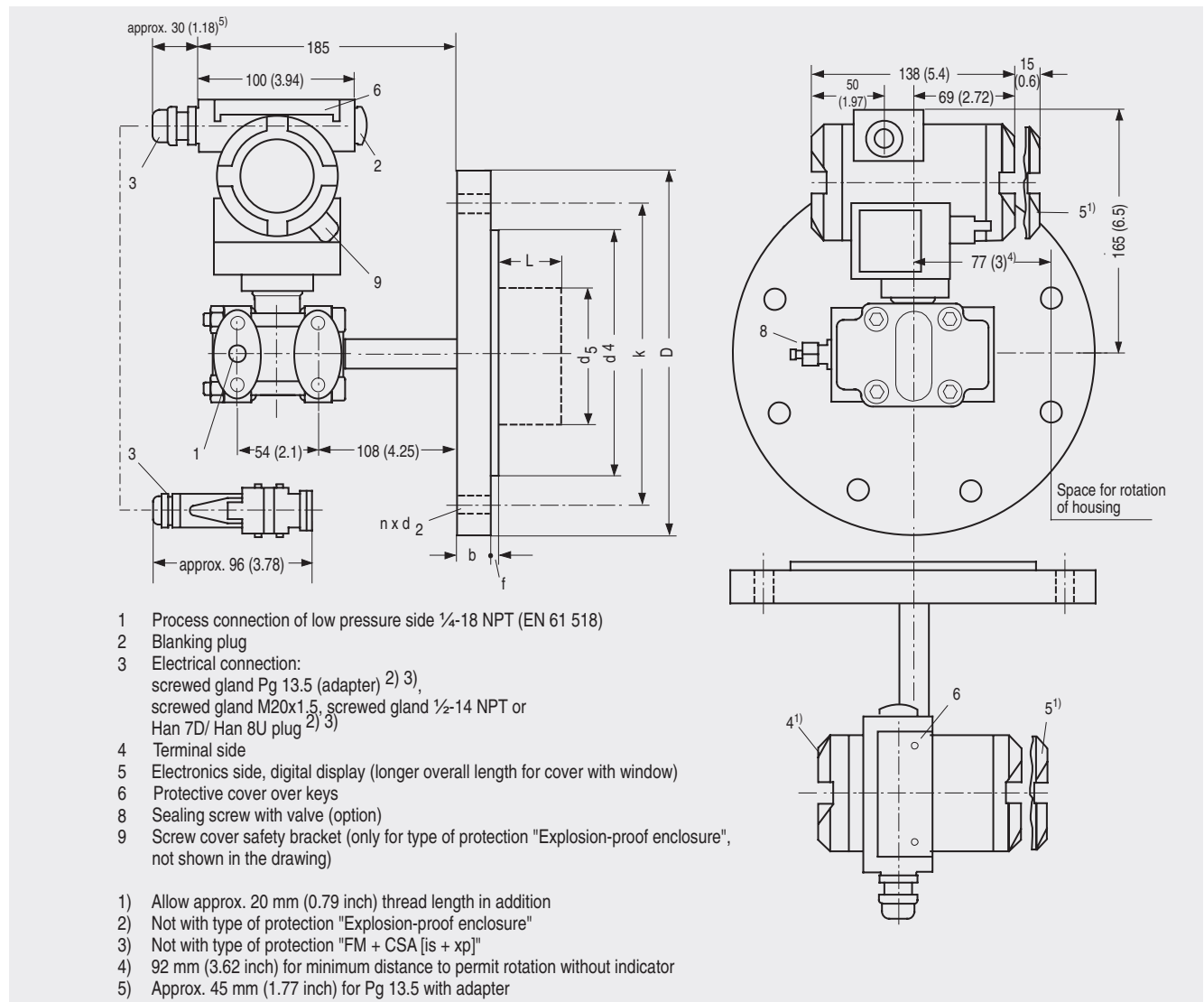

SITRANS P pressure transmitters, DS III series for level, including mounting flange, dimensional drawing, dimensions in mm (inch)

Connection to EN 1092-1

Nom. diam.	Nom. press.	b	D	d	d ₂	d ₄	d ₅	d _M	f	k	n	L
		mm	mm	mm	mm	mm	mm	mm	mm	mm	mm	mm
DN 80	PN 40	24	200	90	18	138	76	72 ¹⁾	2	160	8	0, 50, 100, 150 or 200
DN 100	PN 40	20	220	115	18	158	94	89	2	180	8	
	PN 40	24	235	115	22	162	94	89	2	190	8	

Connection to ASME B16.5

Nom. diam.	Nom. press.	b	D	d ₂	d ₄	d ₅	d _M	f	k	n	L
	lb/sq.in.	inch (mm)	inch (mm)	inch (mm)	inch (mm)	inch (mm)	inch (mm)	inch (mm)	inch (mm)	inch (mm)	inch (mm)
3 inch	150	0.94 (23.8)	7.5 (190.5)	0.75 (19.0)	5 (127)	3 (76)	2.81 ¹⁾ (72)	0.06 (1.6)	6 (152.4)	4	0, 2, 3.94, 5.94 or 7.87 (0, 50, 100, 150 or 200)
	300	1.12 (28.6)	8.25 (209.5)	0.87 (22.2)	5 (127)	3 (76)	2.81 ¹⁾ (72)	0.06 (1.6)	6.69 (168.3)	8	
4 inch	150	0.94 (23.8)	9 (228.5)	0.75 (19.0)	6,19 (157.2)	3,69 (94)	3,5 (89)	0.06 (1.6)	7,5 (190.5)	8	
	300	1.25 (31.7)	10 (254)	0.87 (22.2)	6,19 (157.2)	3,69 (94)	3,5 (89)	0.06 (1.6)	7,88 (200)	8	

d: Internal diameter of gasket to DIN 2690
 d_M: Effective diaphragm diameter

¹⁾ 89 mm = 3½ inch with tube length L = 0.

SITRANS P measuring instruments for pressure

Transmitters for pressure, absolute pressure, differential pressure, flow and level

DS III series for level

2

Selection and Ordering data		Order No.	Further designs	Order code
SITRANS P pressure transmitters, DS III series for level		7 MF 4 6 3 3 -	Please add "-Z" to Order No. and specify Order code.	
2-wire system		■ Y ■ ■ - ■ ■ ■ ■	O-rings for process flanges (instead of FPM (Viton))	
Measuring cell filling	Measuring cell cleaning		<ul style="list-style-type: none"> • PTFE (Teflon) • FEP (with silicone core, approved for food) • FFFM (Kalrez, compound 4079) • NBR (Buna N) 	A20 A21 A22 A23
Silicone oil	Standard	1	Plug	
Measured span			<ul style="list-style-type: none"> • Han 7D (metal, gray) • Han 8U (instead of Han 7D) 	A30 A31
25 ... 250 mbar (0.363 ... 3.63 psi)		D	Sealing screws	A40
25 ... 600 mbar (0.363 ... 8.70 psi)		E	¼-18 NPT, with valve in material of process flanges	
53 ... 1600 mbar (0.77 ... 23.2 psi)		F	Rating plate inscription (instead of German)	
0.16 ... 5 bar (2.32 ... 72.5 psi)		G	<ul style="list-style-type: none"> • English • French • Spanish • Italian 	B11 B12 B13 B14
Process connection of low-pressure side			English rating plate	B21
Female thread ¼-18 NPT with flange connection			Pressure units in inH ₂ O or psi	
• Mounting thread M10 to DIN 19213		0	Manufacturer's test certificate M (calibration certificate)	C11
• Mounting thread 7/16-20 UNF to EN 61518		2	to DIN 55350, Part 18 and to ISO 8402	
Non-wetted parts materials			Acceptance test certificate B	C12
Process flange screws	Electronics housing		to EN 10204-3.1.B	
Stainless steel	Die-cast aluminium	2	Factory certificate	C14
Stainless steel	Stainless steel precision casting	3	to EN 10204-2.2	
Design			Certificate "Functional Safety (SIL)"	C20
• Standard design		1	Setting of upper limit of output signal to 22.0 mA	D05
• International version, English label inscriptions, documentation in 5 languages on CD		2	Type of protection IP68	D12
			(not together with Han 7D / Han 8U plug, Pg 13.5 screwed gland)	
Explosion protection			Use in or at zone 1D/2D	E01
• without			(only together with type of protection "Intrinsic safety (EEx ia)")	
• with ATEX, Type of protection:			Use at zone 0	E02
- "Intrinsic safety (EEx ia)"		A	(only together with type of protection "Intrinsic safety (EEx ia)")	
- "Explosion-proof (EEx d)" ¹⁾		B	Overfilling safety device for flammable and non-flammable liquids	E08
- "Intrinsic safety and explosion-proof enclosure (EEx ia + EEx d)" ²⁾		D	(max. PN 32, only together with type of protection "Intrinsic safety (EEx ia)", to WHG and VbF)	
- "n (zone 2)"		P	Interchanging of process connection side	H01
- "Intrinsic safety, explosion-proof enclosure and dust explosion protection (EEx ia + EEx d + zone 1D/2D)" ²⁾		R		
• with FM + CSA, Type of protection:				
- "Intrinsic safety and explosion-proof (is + xp)" ¹⁾		NC		
Electrical connection / cable inlet				
• Screwed gland Pg 13.5 ³⁾				
• Screwed gland M20x1.5		A		
• Screwed gland ½-14 NPT		B		
• Han 7D plug (plastic housing) incl. mating connector ³⁾		C		
		D		
Display				
• without (digital indicator hidden, setting: mA)				1
• with visible digital indicator				6
• with customer-specific digital indicator (setting as specified, Order code "Y21" required)				7

Ordering information:

1st order item: Pressure transmitter 7MF4633-...
2nd order item: Mounting flange 7MF4912-3...

Example of ordering:

Item line 1: 7MF4633-1EY20-1AA1-Z
B line: Y01
C line: Y01: 80 to 143 mbar (1.16 to 2.1 psi)
Item line 2: 7MF4912-3GE01

Power supply units see "SITRANS I power supply units and input isolators".

Included in delivery of the device:

- Brief instructions (Leporello)
- CD-ROM with detailed documentation
- Sealing plug(s) or sealing screw(s) for the process flanges(s)

- 1) Without cable gland, with blanking plug
- 2) With enclosed cable gland EEx ia and blanking plug
- 3) Not together with type of protection "Explosion-proof"

SITRANS P measuring instruments for pressure

Transmitters for pressure, absolute pressure, differential pressure, flow and level

DS III series for level

2

Further designs	Order code
Please add "-Z" to Order No. and specify Order code.	
Additional data	
Measuring range to be set	Y01
specify in plain text: Y01: ... up to ... mbar, bar, kPa, MPa, psi	
Measuring point number/identification	Y15
max. 16 characters, specify in plain text: Y15:	
Measuring point text	Y16
max. 27 characters, specify in plain text: Y16:	
Entry of HART address (TAG)	Y17
max. 8 characters, specify in plain text: Y17:	
Setting of pressure indicator in pressure units	Y21
specify in plain text (standard setting: mA): Y21: mbar, bar, kPa, MPa, psi, ... Note: The following pressure units can be selected: bar, mbar, mm H ₂ O ⁺ , inH ₂ O ⁺ , ftH ₂ O ⁺ , mmHG, inHG, psi, Pa, kPa, MPa, g/cm ² , kg/cm ² , mA, Torr, ATM or %) Reference temperature 20 °C	
Setting of pressure indicator in non-pressure units	Y22 ¹⁾ + Y01
specify in plain text: Y22: up to l/min, m ³ /h, m, USgpm, ... (specification of measuring range in pressure units "Y01" is essential, unit with max. 5 characters)	

Only the settings for "Y01", "Y21", "Y22" and "D05" can be made in the factory

1) Not together with over-filling safety device for flammable and non-flammable liquids (Order code "E08")

Selection and Ordering data	Order No.	Ord. code
Mounting flange	7MF4912 -	
directly fitted to pressure transmitter SITRANS P (converter part) for level, for DS III series	3	
Connection to EN 1092-1		
Nom. diam.	Nom. press.	
DN 80	PN 40	D
DN 100	PN 16	G
	PN 40	H
Connection to ASME B16.5		
Nom. diam.	Nom. press.	
3 inch	Class 150	Q
	Class 300	R
4 inch	Class 150	T
	Class 300	U
Other version		Z
Add Order code and plain text: Nominal diameter: ...; Nominal pressure: ...		J 1 Y

Selection and Ordering data	Order No.	Ord. code
Mounting flange	7MF4912 -	
directly fitted to pressure transmitter SITRANS P (converter part) for level, for DS III series	3	
Wetted parts materials		
<ul style="list-style-type: none"> Stainless steel 316L <ul style="list-style-type: none"> Coated with PFA¹⁾ Coated with PTFE¹⁾ Coated with ECTFE¹⁾ Monel 400, mat. No. 2.4360 Hastelloy B2, mat. No. 2.4617 Hastelloy C276, mat. No. 2.4819 Hastelloy C4, mat. No. 2.4610 Tantalum 	A D E 0 F G H J U K Z	
Other version Add Order code and plain text: Wetted parts materials: ... Sealing face, see "Technical data"		K 1 Y
Tube length		
<ul style="list-style-type: none"> without 50 mm (1.97 inch) 100 mm (3.94 inch) 150 mm (5.90 inch) 200 mm (7.87 inch) 	0 1 2 3 4 9	L 1 Y
Other version: Add Order code and plain text: Tube length: ...		
Filling liquid		
<ul style="list-style-type: none"> Silicone oil M5 Silicone oil M50 High-temperature oil Halocarbon oil (for O₂ measurements) Vegetable Glycerin / water²⁾ 	1 2 3 4 5 6 9	M 1 Y
Other version Add Order code and plain text: Filling liquid: ...		

Ordering example see previous page

- For vacuum on request
- Not suitable for use in low-pressure range

Further designs	Order code
Please add "-Z" to Order No. and specify Order code.	
Spark arrester	A01
for mounting on zone 0 (including documentation)	
Manufacturer's test certificate M	C11
to DIN 55.350, Part 18 and to ISO 8402	
Acceptance test certificate B	C12
to EN 10 204-3.1B	
Vacuum-proof design	V04
(for use in low-pressure range)	
Calculation of span of associated pressure transmitter	Y05
(enclose filled-in questionnaire with order) Note: Suffix "Y01" required with pressure transmitter	