

閘閥

GATE VALVE

設計要點 DESIGN DESCRIPTION

- OUTSIDE SCREW AND YOKE
- BOLTED BONNET
- FLEXIBLE WEDGE, FULLY GUIDE
- RENEWABLE SEAT RINGS
- RISING STEM AND NON-RISING HANDWHEEL
- AVAILABLE WITH GEAR OPERATOR
- FLANGED ENDS
- BUTTWELDING ENDS

選用標準 APPLICABLE STANDARDS

- STEEL GATE VALVES, API600
- STEEL VALVES, ANSI B16.34
- FACE TO FACE, ANSI B16.10
- END FLANGES, ANSI B16.5
- BUTTWELDING ENDS, ANSI B16.25
- INSPECTION AND TEST, API 598

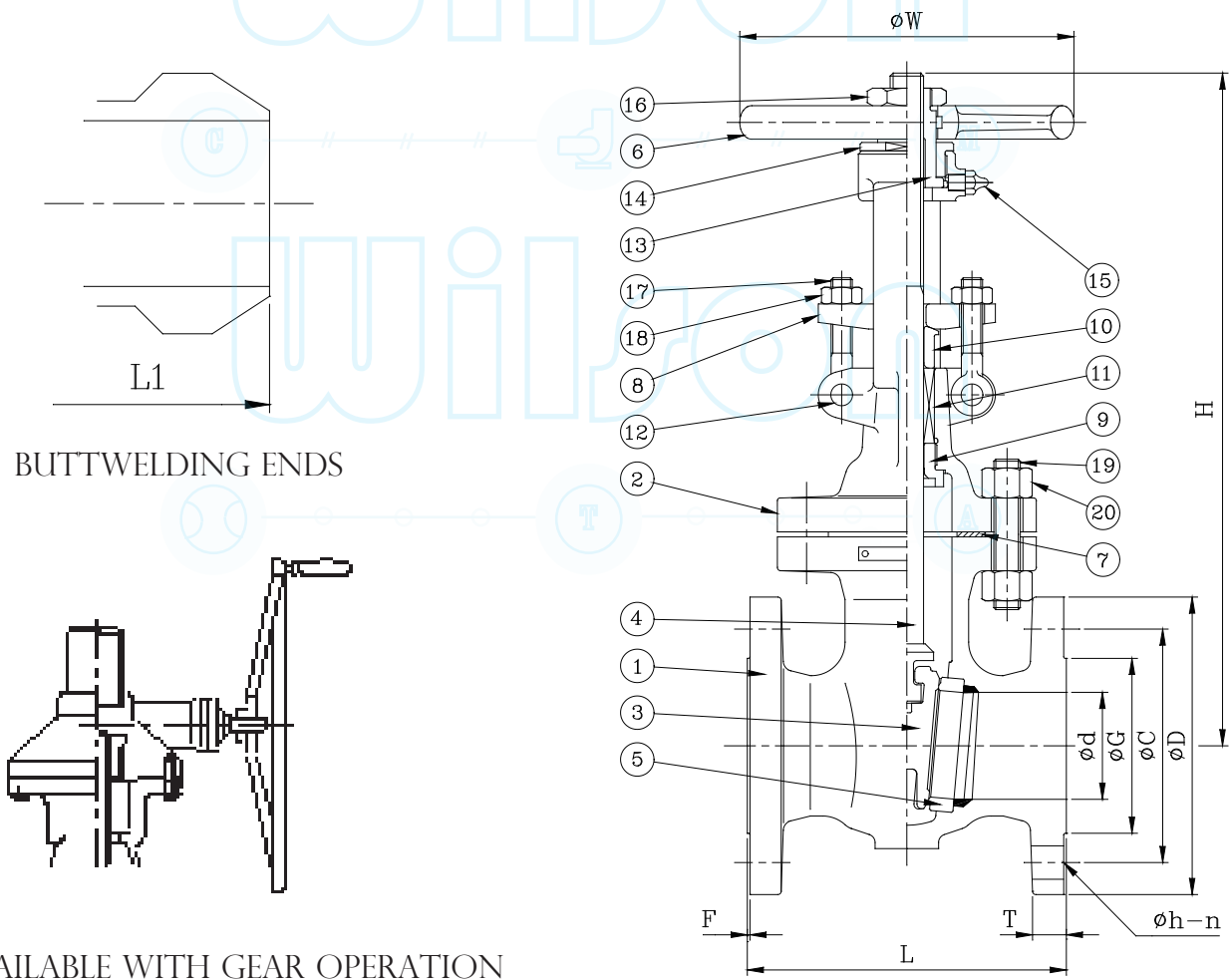

零件與材質 PARTS AND MATERIAL (ASTM)

編號 NO.	零件名稱 PARTS NAME	材質 MATERIALS		
		WCB	WC6	LCB
1	BODY	A216-WCB	A217-WC6	A352-LCB
2	BONNET	A216-WCB	A217-WC6	A352-LCB
3	DISC	A216-WCB+H/F 410	A217-WC6+H/F 410	A352-LCB+H/F 410
4	STEM	A182-F6a		
5	SEAT	A105+H/F STL#6	A182-F+H/F STL36	A350-LF2+H/F STL#6
6	HAND WHEEL	A536		
7	GASKET	SOFT-IRON		
8	GLAND FLANGE	A216-WCB		
9	BONNET BUSH	A276-410		
10	GLAND	A276-410		
11	GLAND PACKING	GRAPHITE		
12	EYE BOLT PIN	A276-410		
13	STEM NUT	A439-D2		
14	RETAINER NUT	A36		
15	NIPPLE	BRASS		
16	WHEEL NUT	A36		
17	EYE BOLT	A193-B7		
18	EYE BOLT NUT	A194-2H		
19	BONNET BOLT	A193-B7	A193-B7	A193-B7M
20	BONNET BOLT NUT	A194-2H	A194-2H	A194-2HM
21	NAME PLATE	A666-304		

其他材質將依照特殊需求 OTHER MATERIALS ARE AVAILABLE UPON REQUEST.

壓力測試 TEST PRESSURE TO API 598

PSIG

SHELL TEST (WATER)	SEAT TEST (WATER)	SEAT TEST (AIR)
2225 (156kg/cm ²)	1628 (114kg/cm ²)	80 (6kg/cm ²)

外形尺寸 DIMENSION TABLE

DN	NPS	φ d	L&LI	H	H _(OPEN)	φ W	T	F	φ D	φ C	φ G	φ h	n	WT.(kg)
50	2	50.8	292	370	440	146	25.4	6.4	165.1	127.0	92.0	19.0	8	37
65	2-1/2	63.5	330	468	543	250	28.5	6.4	190.5	149.4	104.7	22.3	8	56
80	3	76.2	356	475	567	300	31.8	6.4	209.6	168.2	127.0	22.3	8	76
100	4	101.6	432	558	677	350	38.1	6.4	273.1	215.9	157.2	25.4	8	136
150	6	152.4	559	719	894	450	47.8	6.4	355.6	292.1	215.9	28.5	12	285
200	8	200.2	660	858	1085	500	55.6	6.4	419.1	349.3	269.8	31.8	12	460
250	10	247.7	787	999	1277	700	63.5	6.4	508.0	431.8	323.9	35.0	16	730
300	12	298.5	838	1173	1505	800	66.6	6.4	558.8	489.0	381.0	35.0	20	980
350	14	327.2	889	1298	1662	610	69.9	6.4	603.3	527.1	412.8	38.1	20	1380
400	16	374.7	991	1470	1884	610	76.2	6.4	685.8	603.3	469.9	41.0	20	1810
450	18	419.1	1092	1586	2044	610	82.6	6.4	743.0	654.1	533.4	44.5	20	2320
500	20	463.6	1200	1750	2248	610	95.3	6.4	812.8	723.9	635.0	44.5	24	2733