

## SEGMENT VALVE(SINGLE & DOUBLE ACTUATING)

3/4"-18" METAL TO METAL SEATED

WAFER & FLANGE TYPE

Features:

- Nominal pressure rating:  
PN16, 25, 40
- Nominal Size:  
DN 20, 25, 40, 50, 65, 80, 100, 150, 200,  
250, 300, 350, 400.
- Working Temperature: -20°C ~+250°C
- Input Signal:  
0~10 mA, 4~20 mA or 20~100 KPa
- Air Supply: 3~10 Bar G
- Leakage: Class IV
- End Connection: Wafer Type
- Material:



Valve Body,

- (1) SUS 304 (ZG0Cr18Ni9)
- (2) SUS 316 (ZG0Cr18Ni12Mo2Ti)
- (3) SUS 316L (ZG00Cr17Ni14Mo2)

V-ball:

- (1) SUS 316 + Hard chrome plating
- (2) SUS 316L + Hard chrome plating

Seat: Cobalt based hard facing, back seal PTFE lip seal. Substrate,

- (1) SUS 316
- (2) SUS 316L

- Optional Item: E/P position

Test Pressure:

- Shell by Water: 450 PSI (32 Kg/cm<sup>2</sup>)
- Seat by Water: 300 PSI (21 Kg/cm<sup>2</sup>)
- Seat by Air: 80 PSI ( 6 Kg/cm<sup>2</sup>)

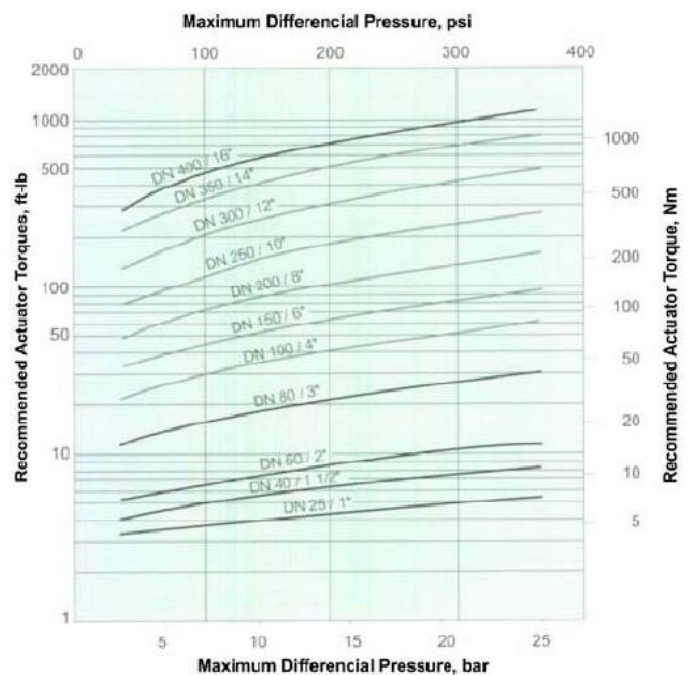

V 型球閥外型主要尺寸 (mm) (雙動致動器&對夾式連接)

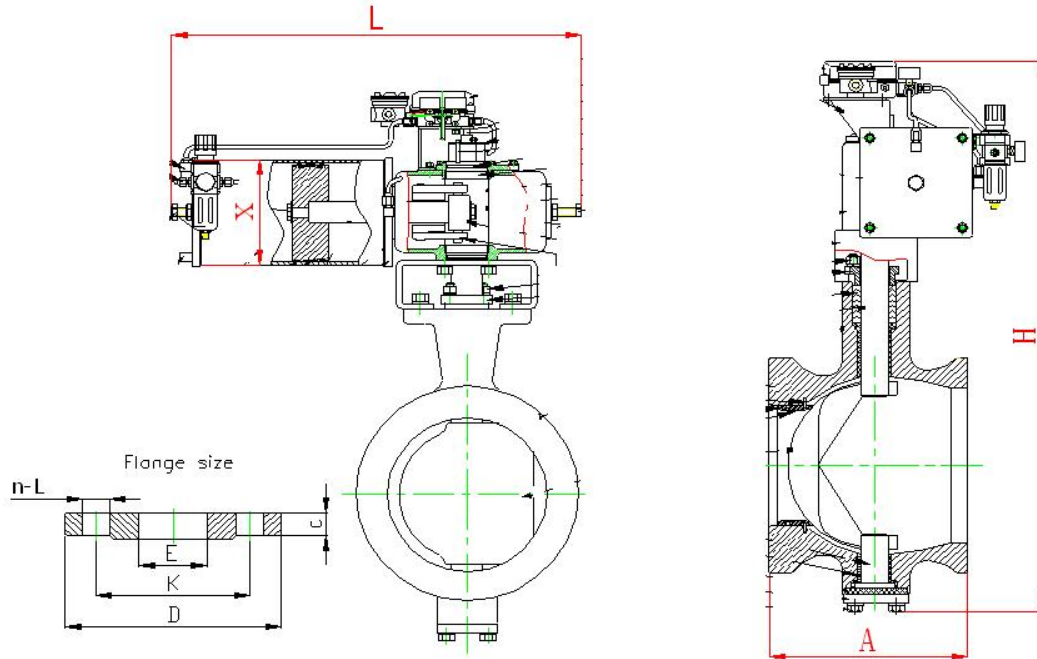

公稱直徑 DN	流量係數 (Kv)	外型主要尺寸Dimension				
		A	L	H	X	閥體淨重(Kgs)
20	20	50	360	410	50	10.4
25	25	50	360	410	50	10.45
32	45	60	360	450	50	11.25
40	63	60	440	480	80	15.05
50	90	75	440	500	80	16.2
65	160	85	440	520	80	16.3
80	250	100	440	560	80	19.55
100	420	115	470	590	100	27.75
125	630	135	470	640	100	33.7
150	900	160	520	700	125	48.70

## V 型球閥外型主要尺寸 (mm) (雙動致動器&法蘭式連接)

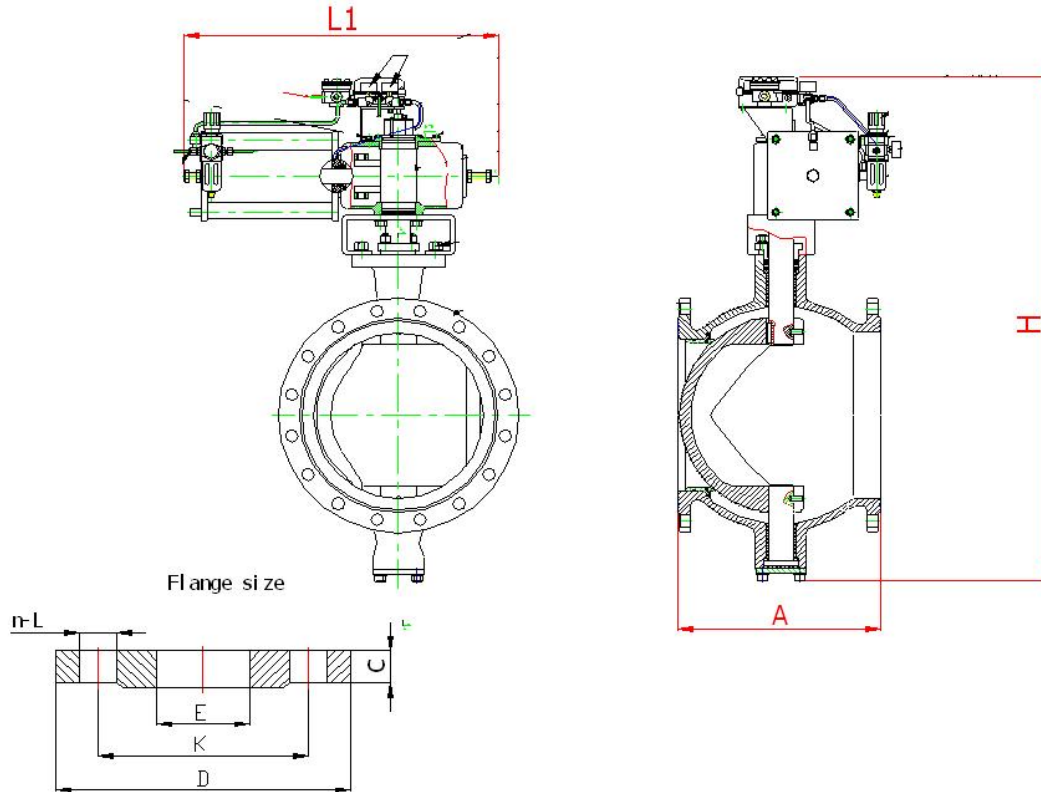

公稱直徑 DN	流量係數 (Kv)	外型主要尺寸Dimension				
		A	L	H	X	閥體淨重(Kgs)
200	1550	243	650	760	125	66.2
250	2550	297	650	860	125	105.5
300	3980	385	690	1040	160	197.55
350	6350	420	730	1150	200	276.55
400	8430	490	860	1290	260	362
450	10820	600	1050	1390	260	459
500	13400	640	1070	1410	260	568

V 型球閥外型主要尺寸 (mm) (單動致動器&對夾式連接)

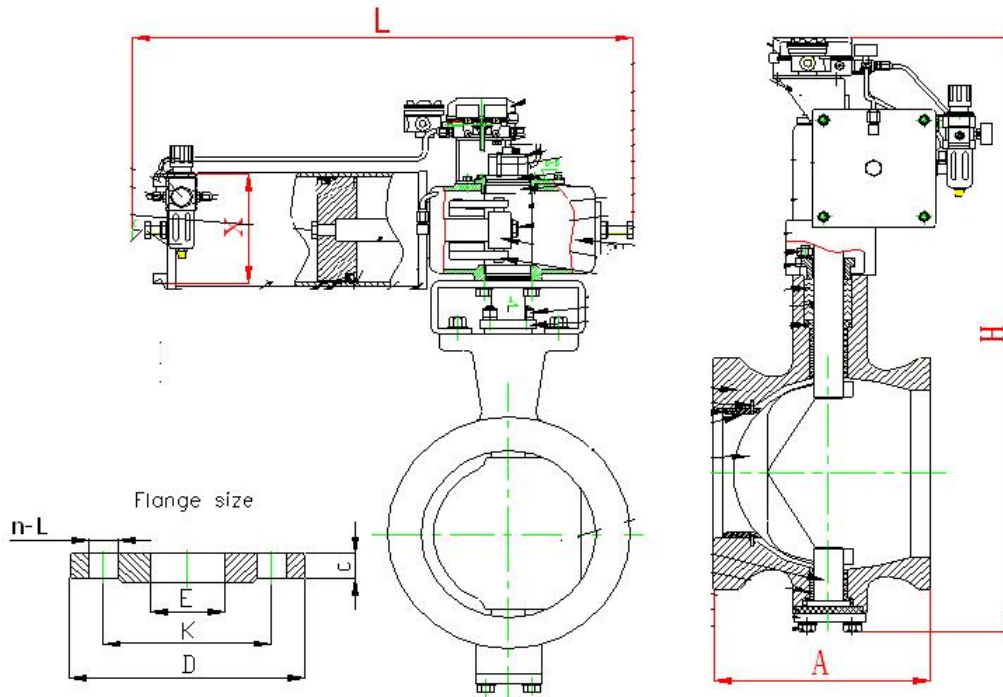

公稱 直徑 DN	流量 係數 (Kv)	外型主要尺寸Dimension				閥體 淨重 (Kgs)
		A	L	H	X	
20	20	50	516	410	100	10.05
25	25	50	516	410	100	10.10
32	45	60	516	450	100	10.10
40	63	60	516	480	100	14.7
50	90	75	516	500	100	15.85
65	160	85	516	520	100	16.95
80	250	100	516	560	125	19.20
100	420	115	516	590	125	27.40
125	630	135	590	640	160	33.35
150	900	160	590	700	160	47.85

V 型球閥外型主要尺寸 (mm) (單動致動器&法蘭式連接)

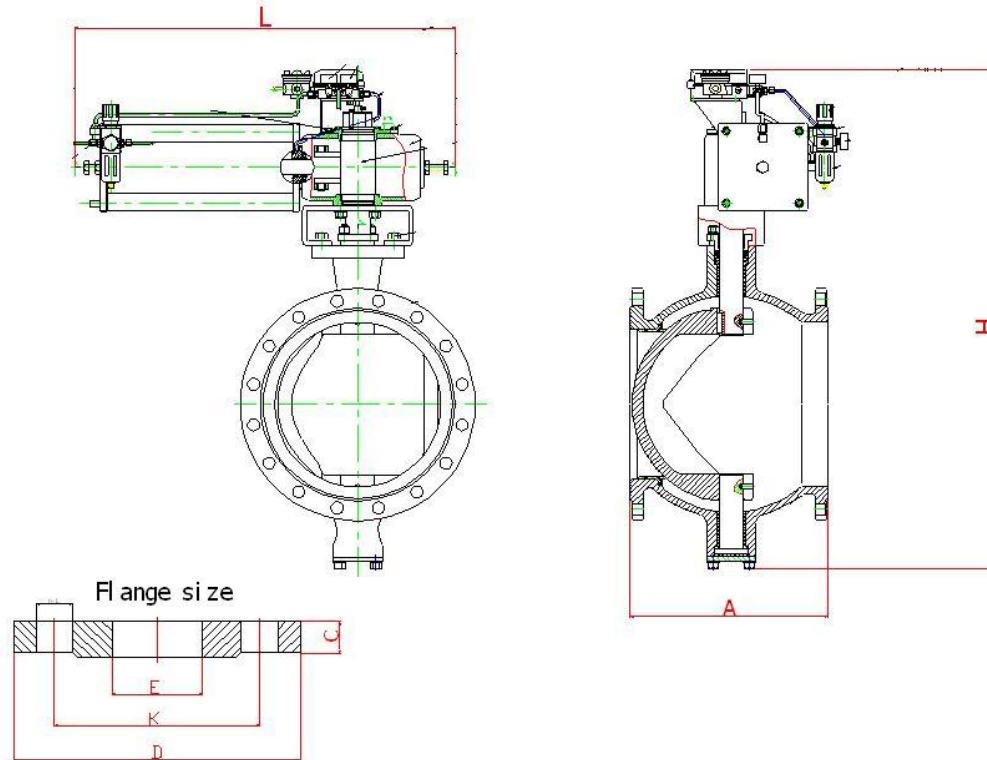

公稱直徑 DN	流量係數 (Kv)	外型主要尺寸Dimension				
		A	L	H	X	閥門淨重(Kgs)
200	1550	243	680	760	160	66.2
250	2550	297	680	860	160	105.5
300	3980	385	810	1040	160	197.55